



ELECTRICAL COMMUNICATION

Technical Journal of the
INTERNATIONAL TELEPHONE AND TELEGRAPH CORPORATION
and Associate Companies

Mr. B. B. Jacobson, East
Mr. W. J. Mitchell.
Mr. W. S. Baly.
Mr. J. Cairns.
Mr. D. W. Smith.
Mr. W. J. Franklin.
Mr. B. L. Clarke.

1942

VOL. 20

No. 3

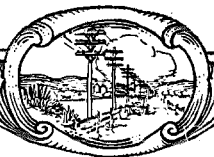

ELECTRICAL COMMUNICATION

Technical Journal of the
INTERNATIONAL TELEPHONE AND TELEGRAPH CORPORATION
and Associate Companies

H. T. KOHLHAAS, Editor

EDITORIAL BOARD

H. Busignies H. H. Buttner G. Deakin E. M. Deloraine Sir Frank Gill W. Hatton
E. S. McLarn Frank C. Page H. M. Pease F. W. Phelan E. D. Phinney Haraden Pratt W. F. Repp

Published Quarterly by the

International Standard Electric Corporation

67 BROAD STREET, NEW YORK, N.Y., U.S.A.

H. M. Pease, President

S. G. Ordway, Secretary and Treasurer

Subscription, \$3.00 per year; single copies, 75 cents

Volume XX

1942

Number 3

CONTENTS

	PAGE
MILESTONES OF COMMUNICATION PROGRESS	143
<i>By H. T. Kohlhaas</i>	
OPERATING RESULTS ON THE NEW BUENOS AIRES-NEW YORK TWIN CHANNEL SINGLE SIDEBAND SHORT WAVE RADIOTELE- PHONE LINK	186
<i>By A. M. Stevens</i>	
DURAND HOSPITAL SIGNALING AND COMMUNICATION EQUIPMENT.	189
<i>By W. White</i>	
DESIGN OF THE OUTPUT STAGE OF A HIGH POWER TELEVISION TRANSMITTER	193
<i>By E. Labin</i>	
THE CONVERSION OF BUENOS AIRES CITY NETWORK TO AUTOMATIC	202
<i>By C. G. Barker, H. E. D. Garnham and W. White</i>	
A NEW 30 Kw SHORT WAVE RADIO TRANSMITTING EQUIPMENT FOR SOUTH AMERICA	217
<i>By F. D. Webster and R. E. Downing</i>	
RECENT TELECOMMUNICATIONS DEVELOPMENTS	229



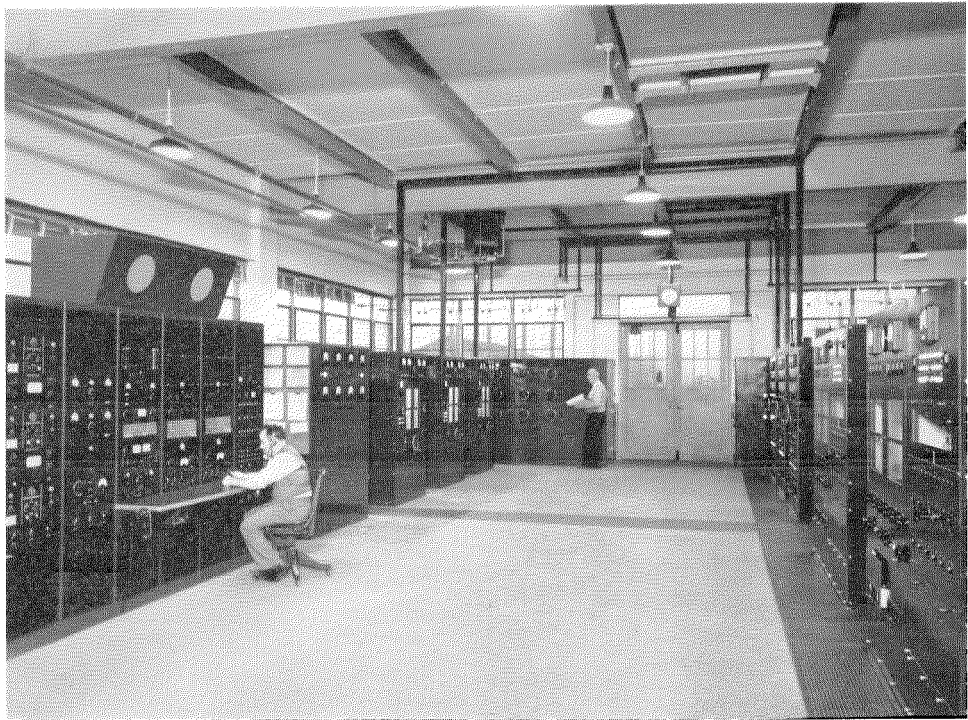

TRANSMITTER ROOM OF THE COLUMBIA BROADCASTING SYSTEM'S 50 KW SHORT WAVE INTERNATIONAL BROADCAST STATIONS WCRC AND WCBX INAUGURATED JANUARY 1, 1942. THE EQUIPMENT WAS DESIGNED AND BUILT BY THE FEDERAL TELEGRAPH COMPANY.

Milestones of Communication Progress

By H. T. KOHLHAAS, E. E., Member A. I. E. E.

Editor, Electrical Communication

In the twenty years that have elapsed since Electrical Communication first appeared, the art of electrical communication has made astonishing progress. Companies in the International Telephone and Telegraph Group throughout the world have contributed generously to this advance, embracing the fields of research, development and manufacture, as well as the development and operation of telephone, telegraph and radio systems—accomplishments which to a considerable degree have been recorded in the pages of this journal. It is felt, therefore, that this review giving the reader what may be regarded as a rather comprehensive perspective of communication developments of this twenty year period will be of interest.

In 1942, Electrical Communication will depart from its normal custom of publishing an international communications review of the previous year because of the impracticability of presenting a comprehensive report of communications activities in a world disturbed by war. In any case, it will be appreciated that many activities cannot at present be discussed.

Introduction

ELECTRICAL COMMUNICATION in 1942 completes its twentieth year of publication. Recorded in its pages are descriptions of developments and activities representing practically all phases of the communication art. It is pertinent, therefore, to examine briefly the picture formed by these publications, using the opportunity to place in their proper perspective some of the principal achievements recorded in the journal.

Taking first the task of planning and coordinating long distance telephone communication, an outstanding event is recorded in the creation in 1924 of the International Consultative Committee on long distance telephony in Europe. It followed a proposal made by Sir Frank Gill in his Presidential Address to the Institution of Electrical Engineers in 1922.^{1, 2, 3, 4}

Achievements in long distance international radiotelephony took place in rapid sequence. Between 1923 and 1926 we find a succession of recorded steps leading to the establishment of the first transatlantic telephone circuit between the United States and England.^{5, 6, 7} In 1930 we read about the first Madrid-Buenos Aires radiotelephone circuit, inaugurated in 1929, followed

shortly by the first radiotelephone circuit between the Americas.^{8 to 16 incl.} In 1931 we read of the first demonstrations of single sideband short wave radiotelephony carried out between Buenos Aires and Madrid and between Madrid and Paris, establishing the now well-recognized improvements in transmission efficiency and the economies which this method makes possible.¹⁷

In 1931¹⁸ and the following years, a series of articles described outstanding developments in the ultra-high frequencies. Long distance telephone communication was established across the English Channel on approximately 1,600 megacycles using very sharp beams. Work in this general field was to be continued with great activity, and publications appeared on propagation of these very high frequencies in 1936 and 1937, the latter including a description of the first multi-channel ultra-short wave telephone link.^{19 to 24 incl.} Later on, work on ultra-high frequencies was directed also to television transmission. On the one hand, we find references to the Eiffel Tower television station in 1939, delivering 30 kw to an exceptionally long feeder over the wide band of frequencies necessary for television;²⁵ on the other, to transmission over dielectric guides with experiments on frequencies from 1,000 mc to 30,000 mc, using various types

of positive grid triodes, klystrons, magnetrons or other tube structures.^{26 to 33 incl.}

High power broadcasting on intermediate frequencies and high frequencies takes a prominent place in these publications. We read in 1932 of the Prague Station with 120 kw carrier,³⁶ followed two years later by the Budapest Station with the same carrier power, and unique for its anti-fading mast antenna over 1,000 feet high, the highest antenna ever constructed.^{37,38}

On higher frequencies, mention was made of two British Empire broadcasters added in 1937 at Daventry, rated at 50 kw carrier power at 22 megacycles.³⁹

Early long distance telephone communication to ships at sea is also recorded:^{40,41} on the *Beren-garia* in 1929; the *Belgenland* in the winter of 1930-31 and the *Empress of Britain* in 1931-32. Remarkable results were obtained; for example, successful conversations were held with London when a ship was in the China Sea and with New York when at Alexandria. Service to the *Majestic* was opened on February 14, 1930, at first for incoming calls only.

References to important work done on automatic direction finders are found in several articles. An airplane automatic radio compass was described in 1936. This equipment was introduced in the United States in 1937, and important experiments were made and papers published on night error and mountain effects.^{42,43,44}

The subject of ground direction finders avoiding polarization errors by the use of spaced vertical antennae with H.F. transmission line to distant receivers is also found in these pages, as is that of aerial navigation.^{43,45,46,47,48}

Less spectacular, but fundamental, are developments in automatic telephony and transmission, fields which are represented in numerous issues of this journal. The general tendencies appear clearly from these articles. Notable is the application of machine switching to large areas, the rapid expansion of rural automatic networks and, in recent years, schemes involving complete national dialing in some of the smaller European countries, either on a timed and zoned metering basis or on an automatic ticketing basis.^{49 to 61 incl.}

These national dialing schemes led to the development of a commercially practicable system for automatic toll ticketing, each ticket containing a complete record of each subscriber's tele-

phone call. We find in 1937, 1939 and 1940 a series of articles showing how automatic toll ticketing was developed and introduced commercially.^{62, 63, 64, 65}

The wire transmission systems went through an evolution just as remarkable as that of automatic switching. We find references to the first carrier telephone systems in Brazil and Australia in 1924 and 1925, respectively;^{66, 67} the first loaded and repeated long distance French telephone cable in 1927;⁶⁸ and the first twelve-channel carrier systems and the first coaxial cable in England in 1937.^{69, 70}

Through these articles, prepared and published year after year, often when the value of new systems was not yet fully established or even appreciated, we can sense the enthusiastic and coordinated effort of an organization confronted with many problems, but with experience and personnel drawn from all parts of the world; an organization mainly under the general technical guidance and licensing of the International Standard Electric Corporation, which, in a period covering approximately twenty years, has created an extensive research and development organization and a manufacturing organization capable of producing the everchanging and increasingly exacting matériel for the electrical communication and its many related fields.

Several lines of development, continued with confidence year after year, are only now yielding their reward in connection with war efforts. This is especially true of much of the work done on aerial navigation, on direction finding and in the general field of ultra-high frequencies.

The Communication Art in 1922

An indication of the state of the art in 1922 may be gleaned through quotations from an article by the late J. L. McQuarrie.⁷¹

"It is indeed fascinating to speak by wire with friends and business associates located within the same community, but with what a feeling of amazement does one engage in a long distance conversation and wonder at the marvelous possibilities of the telephone . . . in the year 1915, conversation was carried on between New York and San Francisco, a distance of 3,400 miles. This was accomplished by means of wires strung on poles over the vast stretches of prairie and

mountainous country which lie between the central and western sections of the United States.”

* * *

“Cables had been used for comparatively short lines within city boundaries, but they were not suitable for long distance communications. Improvements in design permitting the use of cables over long distances are among the most noteworthy in the development of the telephone art. It is now possible to communicate through cables over distances as great as those bridged in the past by overhead wires; in fact, a cable is now being installed for long distance service between New York and Chicago, nearly 1,000 miles in length.

“The attenuation of voice currents through submarine cables is greater than in the case of land cables, but even this obstacle has been surmounted. Three such cables (the longest in the world) were laid between the United States and Cuba in 1921, thus providing a telephone link between the cities of these two countries. An interesting feature of the design is that although each cable contains but a single path for a telephone circuit, the telephone path also provides two superimposed duplexed telegraph circuits.

“With its field of application as yet undetermined, but possessing important commercial possibilities, considerable study has been given to the development of radiotelephony and in 1915 spoken words were successfully transmitted by radio from Washington to Paris and Honolulu, the Paris message being the first telephone communication to bridge the Atlantic Ocean. During the past year radiotelephony has been applied to the commercial system in the form of a radio toll circuit between the coast of California and Catalina Island, a distance of about 30 miles. . . .

“Another notable demonstration of the interconnection of land lines and radio stations occurred recently when telephone communication was established between subscribers’ stations in the United States and a transatlantic steamship located 300 miles from shore.

“A most interesting exhibition of long distance communication occurred in 1921, when commercial conversation was carried on between Havana, Cuba and Catalina Island, in the Pacific Ocean, a total distance of 5,730 miles; the circuit

comprised 5,600 miles of land lines, 100 miles of submarine cable and 30 miles of radio.

“Multiplex telephony has been the dream of inventors for years and it has finally been achieved. A system has been devised and placed in commercial service which provides five commercial telephone channels over one pair of wires, and through the application of the principles of this system to telegraphy, ten duplexed telegraph channels may be secured over a single circuit.

“A novel application of radiotelephony is the distribution of music and speech from central or ‘broadcasting’ stations in such a manner that homes equipped with comparatively simple and inexpensive apparatus may receive lectures, music, weather reports, market quotations and other useful information and entertainment.

“One of the most recent developments is that of the loud speaking telephone used with marked success in connection with public addressing, both in and out of doors. On one occasion an assembly of 125,000 people, in an area of six acres, was able to hear the speaker without difficulty. By association with the commercial telephone service, speech may be transmitted to assemblages at points far distant from that at which the address is being delivered. At the recent memorial services at the National Cemetery at Arlington, Virginia, the address of the President of the United States was distinctly heard by an audience of 100,000 people at Arlington, 30,000 at New York and 20,000 at San Francisco. Loud speaking telephones are also being used in connection with radio receiving sets, thereby materially increasing the popularity of the ‘broadcasting’ service.

“Automatic telephone equipments, so arranged that stations may call one another without the intervention of an operator, have been in use for some time, but they have not been suitable for service in the larger metropolitan areas. The intricate traffic problems of these localities required a new type of system, which has been perfected and is now being installed in the larger cities.”

International Consultative Committee of Long Distance Telephony (C. C. I. F.)

In 1922 Frank Gill (now Sir Frank, K.C.M.G., O.B.E.) “was elected President of the Institution of Electrical Engineers of which he had

been a member since 1891 and selected as the subject of his inaugural address Electrical Communications with particular reference to international telephony. He drew attention to the achievements of the American Telephone & Telegraph Company in long distance telephony and pointed out that if distances alone were considered, telephone conversations could be carried on to all parts of the Continent of Europe and beyond with equal facilities. Long distance telephony had been possible in the U. S. A. because there had been one planning and coordinating authority, whereas there were some 40 in Europe, all with different ideas. Unless the circuit had been planned throughout with the same electrical characteristics, reflection and other losses occurred wherever there were variations. He proposed three alternative plans for dealing with this situation, one of which provided for an international telephone organization with supervisory engineering powers. Early in 1923 the Department of Posts, Telegraphs & Telephones in France called an international meeting, of Government officials only, to consider these proposals and in 1924 the International Consultative Committee of Long Distance Telephony (C. C. I. F.) was formed, based on Mr. Gill's third proposal. To the efforts of this Committee we owe the success of long distance telephony in Europe, but the formation of the Committee is due to the vision of Mr. Gill." ^{1, 2, 3, 4, 159}

Transatlantic Radio Telephony

(a) 1923 TESTS

On Sunday, January 14, 1923, while seated in his office at the New Southgate plant of the International Western Electric Company (now the International Standard Electric Corporation), Frank Gill (now Sir Frank), then European Chief Engineer of the International Western Electric Company, together with Postal officials of the British Government, listened for two hours to H. B. Thayer, then President of the American Telephone and Telegraph Company, and others talking from Mr. Thayer's office on the 26th floor of 195 Broadway, New York. Among others, a message was received in New York from London reading:

"Loudspeaker now being used—good results—

great enthusiasm. Your interview on loudspeaker came through fine."

These tests recorded a distinct advance in the art over the transatlantic tests of 1915. A 5,400 metre wave was used; the output delivered to the antenna was 100 kw (peak power of single sideband).⁵

(b) TRANSATLANTIC TRANSMISSION

The one-way 1923 transatlantic radio transmission tests, referred to above, were conducted during the relatively favorable winter months, and it was appreciated that inauguration of radiotelephone transatlantic service undertaken on a sound engineering basis would require an extensive study of transmission characteristics. The carrying on of the extensive measurement program involved was possible through the cooperation of the American Telephone and Telegraph Company, the Radio Corporation of America and its associated companies, as well as the International Western Electric Company* and the British Post Office.

A paper⁶ in the nature of a report was presented before the I.R.E., May 6, 1925, giving an analysis of observations of long wave transmission across the Atlantic over a period of about two years. Important conclusions were drawn involving effects due to solar radiation, illuminated and darkened hemispheres, disturbances in the earth's magnetic field, etc. It was pointed out that, in general, static noise is lower at the higher frequencies.

(c) BRITISH GENERAL POST OFFICE RADIO STATION AT RUGBY

Interest engendered by the experiments in two-way transatlantic radiotelephony focused at the British end in the Rugby Station of the G. P. O. This station, notable for its size and many novel features was described in 1926.⁷

Essentially the equipment consisted of the single sideband input, the high power radio amplifier and the necessary system of controls and protective arrangements.

Typical measured values when working on one portion of the aerial only, viz., that having a capacity of 0.33 μ F, are cited as of interest.

* Predecessor of International Standard Electric Corporation.

Aerial Circuit Power—257–306 kw

d-c Input Power—355–434 kw

Filament Power—48 kw

Efficiency Excluding Filament—72%

Efficiency Including Filament—64%

Voltage on Antenna—165,000–180,000 volts.

(d) TRANSATLANTIC TELEPHONY BETWEEN THE
INSTITUTION OF ELECTRICAL ENGINEERS,
LONDON, AND THE AMERICAN INSTITUTE
OF ELECTRICAL ENGINEERS, N. Y.^{7a}

“On Thursday, February 16, 1928, a demonstration of transatlantic telephony was given between the Institution of Electrical Engineers, London, and the American Institute of Electrical Engineers, New York, in joint session. By preliminary agreement, arrangements were made for receiving and for sending telephonic messages from the Council Rooms of the respective institutions and, in the case of London, provision was made by the British Post Office whereby an audience consisting chiefly of electrical engineers could listen in their Lecture Theatre to the proceedings, by the aid of a loudspeaker.”

* * *

“MR. ARCHIBALD PAGE (London): I regard it as a great honour to be asked to take the chair on this historic occasion; it is also a gracious compliment to our Institution, and in accepting, which I do gladly, I desire to thank you, Mr. President, and the Members of the American Institute of Electrical Engineers most heartily. I welcome all present at the meeting now in session, and venture to predict that the proceedings will prove exceedingly interesting and likely to live not only in our memories, but to be quoted by succeeding generations of electrical engineers, as marking an important milestone in the advancement of electrical science.”

* * *

“GENERAL J. J. CARTY (New York): Whereas, On this sixteenth day of February, 1928, the members of the Institution of Electrical Engineers assembled in London, and the members of the American Institute of Electrical Engineers assembled in New York, have held, through the instrumentality of the transatlantic telephone, a joint meeting at which those in attendance in both cities were able to participate in the proceedings, and hear all that was said, although the

two gatherings were separated by the Atlantic Ocean; and as this meeting, the first of its kind, has been rendered possible by engineering developments in the application of electricity to communication by telephone; therefore,

“Be it Resolved, That this meeting wishes to express its feelings of deep satisfaction that, by the electrical transmission of the spoken word, these two national societies have been brought together in this new form of international assembly, which should prove to be a powerful agency in the increase of good-will and understanding among the nations; and

“Be It Further Resolved, That a record of this epoch-making event be inscribed in the minutes of each society.”

“THE CHAIRMAN (London): Sir Oliver Lodge, who needs no introduction, is sitting beside me, and I have asked him to second the motion

“SIR OLIVER LODGE (London): It is surely right and fitting that a record of the transmission of human speech across the Atlantic be placed upon the minutes of those societies whose members have been instrumental in making such an achievement possible, and I second the proposal that has just been made from America.

“All those who in any degree have contributed to such a result—from Maxwell and Hertz downwards, including all past members of the old British Society of Telegraph Engineers—will rejoice at this further development of the power of long distance communication. Many causes have contributed to make it possible. That speech is transmissible at all, is due to the invention of the telephone. That speech can be transmitted by ether waves is due to the invention of the valve, and the harnessing of electrons for that purpose. That ether waves are constrained by the atmosphere to follow the curvature of the earth's surface is an unexpected bonus on the part of Providence, such as is sometimes vouchsafed in furtherance of human effort. The actual achievement of today at which we rejoice, and which posterity will utilise, must be accredited to the enthusiastic cooperation, and to the scientific and engineering skill of many workers in the background, whose names are not familiar to the public, as well as to those who are well known.

“The union and permanent friendliness of all branches of the English-speaking race, now let us hope more firmly established than ever, is an

asset of incalculable value to the whole of humanity. Let no words of hostility be ever spoken."

"THE CHAIRMAN (London): Gentlemen, you have heard the Motion proposed by General Carty, and seconded by Sir Oliver Lodge. I now put it to the joint meeting. 'Those in favour.' 'Contrary.' 'Carried unanimously.'"

Short Wave Radiotelephone Links

(a) MADRID-BUENOS AIRES

Officially inaugurated in October, 1929, the Madrid-Buenos Aires radio link provided telephone subscribers with inter-continental and international facilities of the most modern type. The plans formulated by the International Tele-

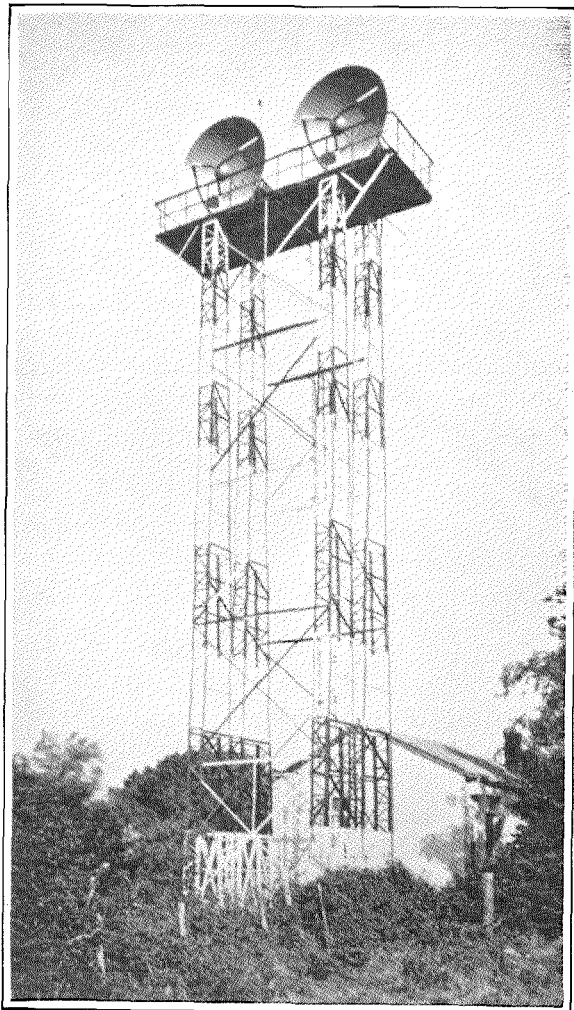

Micro-Ray Towers (20 metres high).

phone and Telegraph Corporation provided for connecting associate companies in South American telephone operating areas with the Spanish telephone network and, in addition, through Spain to other European networks.

Development was commenced at a time when knowledge of short wave telephony was meagre and the project required the solution of many special problems, including both the radio and low frequency portions of the equipment.^{8 to 15 incl.}

The transmitting equipment designed by the International Telephone and Telegraph Laboratories, Inc., operated initially with a maximum of 12 kw peak power and the modulator circuits to permit 90 percent to 100 percent linear modulation.

(b) NEW YORK-BUENOS AIRES

The opening of radio facilities between New York and Buenos Aires, April 3, 1930, connecting 277,000 (now about 583,000) telephones in Argentina, Chile and Uruguay with 21,600,000 (now more than 25,000,000) telephones in the United States, Canada, Mexico and Cuba marked another important step in national and inter-continental telephonic communication.¹⁶ Through the transatlantic radiotelephone service between New York and London, Buenos Aires and Madrid, and then New York and Buenos Aires, the telephone networks of three continents were placed in actual or potential contact with one another.

The New York-Buenos Aires link was the first two-way telephone circuit between the Americas. Like the other links just referred to, it is a true radiotelephone trunk line providing service to the entire telephone networks involved.

Subsequent to the opening of the Buenos Aires-New York link, companies in the I. T. T. group constructed radio stations in other South American countries providing telephone service to many countries and forming an extensive continental telephone network, serviceable also as point-to-point links in radio broadcasting.^{72*}

(c) DISPLACED SIDEBAND ON SHORT WAVE LINKS

During early tests of radiotelephone circuits on wavelengths below 100 metres, fading in par-

* See also article in this issue, "Operating Results on the New Buenos Aires-New York Twin Channel Single Sideband Short Wave Radiotelephone Link."

ticular was prominent. Research disclosed that it involved three separate aspects: diurnal variation, general fading and selective fading. These phenomena were discussed and analyzed mathematically in 1931^{16a} with special reference to selective fading, it being assumed that sideband frequencies could be located sufficiently far from the carrier to be affected independently.

The study showed that improvement both in reliability and quality of transmission could be effected by the application of the displaced sideband method, and its use by I. T. & T. companies has proved distinctly advantageous. Examples are the Madrid-Buenos Aires and the Buenos Aires-Rio de Janeiro short wave radio links. In the latter, during heavy traffic periods, the displaced sideband system has been successfully combined with the usual type of transmission to give two commercial telephone channels. With good filters, this service is entirely satisfactory and gives added secrecy to the circuits.

Micro-Ray Radio

(a) DUPLEX TELEPHONY ACROSS THE STRAITS OF DOVER— MARCH 31, 1931¹⁸

“Ultra-short wave radiotelephony and telegraphy, known as Micro-ray Radio, was demonstrated successfully between Dover and Calais on March 31, 1931, by the International Telephone and Telegraph Laboratories, Inc., of England, in cooperation with the Laboratories of Le Matériel Téléphonique, of France (also comprised in the I. T. & T. group of companies). The equipment was largely developed by French engineers in the Paris laboratories.

“The Micro-ray System employs transmitting and receiving antennae only 2 cm in length. It has a wavelength as low as 18 cm and requires power of only one-half a watt.* . . . The conversations exchanged between Dover and Calais were of high quality and well up to the standard of the best telephone transmission.”

* * *

“The *Electrical Review* (April 10, 1931) under the caption ‘Short Wave Radio Telephony,’ in

* Radiation emitted from the antenna was concentrated into a very sharp beam by means of the main paraboloidal reflector. The gain of this reflector alone was of the order of 28 db; it became 33 db when the additional reflector (spherical) was added to the system.²⁰

connection with the Micro-ray, commented editorially:

“One of the major problems of radio communication today is the crowded condition of the ether. Indeed, the bogey of congestion is so menacing that serious attempts are being made internationally to evolve some workable scheme of virtually rationing frequencies, whilst it has also provided the impetus to explore the possibilities of the shorter wavelengths. The use of the 5- to 50-metre range is satisfactory for long distance commercial communication, but, while the directive properties of short waves tend to simplify the avoidance of mutual interference, practical difficulties of application unfortunately increase progressively with increase of frequency. So acute did the situation become as to induce investigation even within the range of three metres, below which known technique does not appear to have been attended with any substantial degree of success. What was seemingly needed was some radical change in method, and it was an advance of that magnitude which was demonstrated successfully last week . . . as the culmination of work commenced about a year ago in a new field—so different from the existing one as to justify another name. Subject to entirely different conditions and necessitating a technique of its own, the extreme simplicity of the equipment and its ridiculously small power requirements mark a new epoch in the art of electrical communication.’ ”

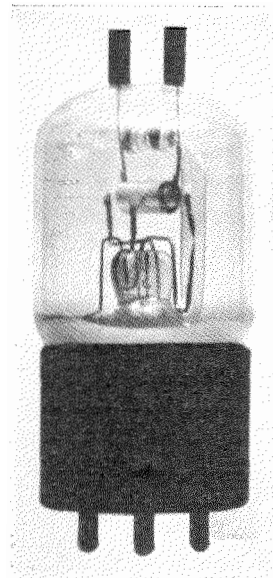

Micro-Ray Oscillating Tube.

* * *

“A distinguished group of officials of the British Government and Military and Naval Attachés from various countries, leading scientists, and representatives of the press attended a demonstration at Dover while a similar group of French Government officials and guests came

from Paris to Calais to participate in the demonstration."

* * *

Following the demonstration mentioned above, an order was received for a permanent link operating between Lympne, England and St. Inglevert, France, a distance of 56 kilometres.

In July, 1933, an article,¹⁹ mainly theoretical, was published on the production and utilization of micro-rays. The main property distinguishing these rays is that use may be made of phenomena which are now commonly regarded as optical, such as reflection, refraction and diffraction.

This link, the first of its kind in the world and used commercially until interrupted prior to the war, employed positive grid triodes both at the transmitting and receiving ends. The two extremities of the oscillating electrode are connected to a transmission line leading to a radiating element (2 cm in length).

The Anglo-French micro-ray link, including the electro-optical system (transmitter and receiver units), micro-ray tube circuits, telephone and teleprinter equipment, was described in some detail in January, 1934.²⁰

Micro-ray generators, receivers and aerial systems, together with results of propagation measurements, were described in April, 1936.²¹

(b) PROPAGATION TESTS WITH AND SUPERHETERODYNE RECEPTION OF MICRO-RAYS

Variations in signal strength had been noted on the 1,700 mc Lympne-St. Inglevert system and extensive tests were undertaken to ascertain what influence a change of wavelength would have on the amplitude and frequency of the fading phenomena.²²

The type of tube used in the tests did not differ from that in regular operation on the Lympne-St. Inglevert micro-ray link. Theoretical considerations showed that the main factor underlying the design of micro-ray tubes for a specified frequency range is the wire length of the oscillating electrode. Further, for a given length of electrode wire, it is practicable to prepare a chart (Fig. 2²²) giving as a function of the transmission line y the wavelengths which can be produced by the tube provided suitable oscillating conditions are obtained inside the structure.

The propagation tests were made on three wavelengths: 18 cm, 20 cm and 29 cm. Effects studied included the tide in the English Channel, local interference (of great importance) in front of the receiving reflector, interference caused by people walking along the cliffs, ships crossing the line of the beam at a certain distance, atmospheric temperature, humidity and wind conditions.

It was found by computation that a combination of two wavelengths would produce signals remaining above 18 db during the following time percentages:

18 cm + 20 cm: 94%
18 cm + 29 cm: 90%
20 cm + 29 cm: 96.6%.

Another interesting result from the tests was the development of a new method for receiving continuous wave micro-ray telegraphy.*

For the reception of waves of frequencies in the neighborhood of 2,000 megacycles, simple detectors with or without reaction or super-reaction usually had been employed. In 1937, a 17 cm superheterodyne receiver with stabilized intermediate frequency was described and its calibration as a signal strength measuring set discussed.²³

Single Sideband Short Wave Telephone Links

As early as the period April, 1930–March, 1931, single sideband tests on short waves were carried out over the following three links:

Buenos Aires to Madrid
Local tests at Madrid (Pozuelo to Griñon, 80 km)
Madrid–Paris

Tests between Paris and Madrid showed that expected improvements over double sideband working were fully realized.

In July, 1931, the application of the single sideband system to short wavelengths was comprehensively discussed, as were the difficulties involved and the advantages to be realized. A possible commercial system was described, including the transmitter and receiver designs, and the problems of synchronization and improvement in signal-noise ratio.¹⁷

* *Brevet Français* 801,196.

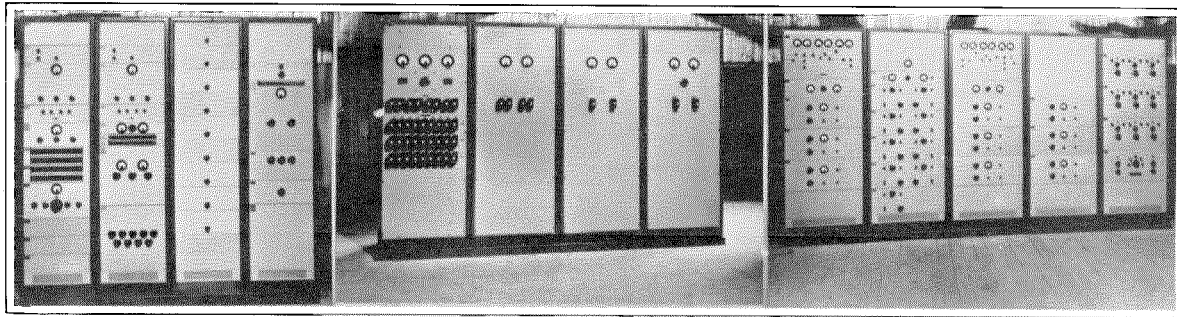

Belfast-Stranraer 9-Channel Ultra-Short Wave Equipment. Stranraer End.

In October, 1933, the importance of reducing operating costs was emphasized inasmuch as only a few existing radio links were working at anything like full load. Further, on an existing typical link, either with light or heavy traffic, the single sideband suppressed carrier system could be expected to save about 87 percent of the valve replacement and 90 percent of the power costs. It was shown also that changing to single sideband working should be equivalent in signal/noise ratio to increasing the peak power of the transmitter about 16 times, thus greatly reducing the size of the transmitter. In addition, the single sideband system eliminates the chief cause of distortion, viz., that due to selective fading out of the carrier.

Among others, questions of independent stable oscillators at each end versus a pilot signal, and a simplified form of commercially applicable receiver, were considered. Mention also was made of several well known privacy schemes, then useless but promising in association with short wave working.

With the then existing equipment, the number of telephone channels available in the short wave band could be only slightly increased by applying the single sideband method, limiting factors being transmitter stability and receiver selectivity; it was pointed out, however, that in the future the limiting factor undoubtedly would be the frequency range occupied by the channels, i.e., the suppression of one sideband on speech circuits would become very important.⁷³

Ultra-Short Wave Communication²⁴

- (a) Single Channel Radiotelephone Circuit Between Barcelona and Majorca.
- (b) Nine-Channel Multiplex Radiotelephone Link Between Scotland and Ireland.

Comparison of the utility of wavelengths between 1 and 10 metres (300 and 30 mc per second) on the one hand, and 14 and 30 centimetres (2,100 and 1,000 mc per second) on the other was made in 1937. The conclusion was reached then that a most useful band for ultra-short wave working lies between 1 and 10 metres. The range between 6 and 3 metres was indicated as ideal for high-grade radiotelephone networks; and, the longer end of the ultra-short wave band seemed most promising for mobile units such as police cars.

The first U.H.F. circuit interconnecting Barcelona and Majorca was opened in 1935. Work on additional circuits, operating in the 60 to 70 megacycle band and linking the three principal Balearic Islands (Majorca, Minorca and Ibiza), was interrupted by the Spanish Civil War, but was completed immediately after its termination in 1939. In addition, a similar circuit was established between Algeciras, Spain, and Ceuta, Spanish Morocco.

The 1941 construction program of the Compañía Telefónica Nacional de España, incidentally, included the following U.H.F. links: (1) Malaga (Spain)—Melilla (Spanish Morocco); (2) Malaga (Spain)—Ceuta (Spanish Morocco); and (3) a second link Algeciras (Spain)—Ceuta (Spanish Morocco).

Broadcasting

(a) PRAGUE, CZECHOSLOVAKIA

Passing over earlier transmitters supplied by the International Standard group of Companies, such as those in England (Birmingham⁷⁴), South Africa,⁷⁵ Denmark, Norway and Sweden,⁷⁶ and Iceland (where a 500 watt equipment initiated broadcasting at Reykjavik, the capital⁷⁷),

the Prague High Power Broadcasting equipment was described in January, 1932.³⁶ Its rating, according to C.C.I.R. definition, was 200 kw and at the time it probably was the most powerful broadcaster operating in Europe. It was

designed to be capable of 100 percent distortionless modulation when delivering 120 kw carrier power to the antenna, i.e., the power which could be delivered by the valves in the final stage feeding the antenna was 480 kw. Modulation took

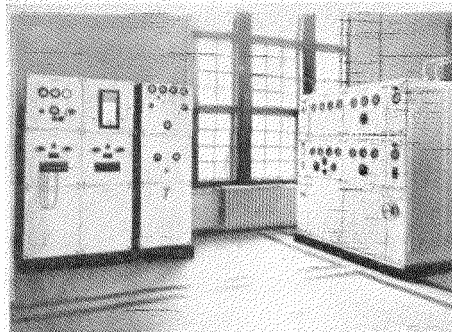

LINE AMPLIFIER HIGH STABILITY MASTER
OSCILLATOR AND OSCILLATOR MODULATOR UNIT

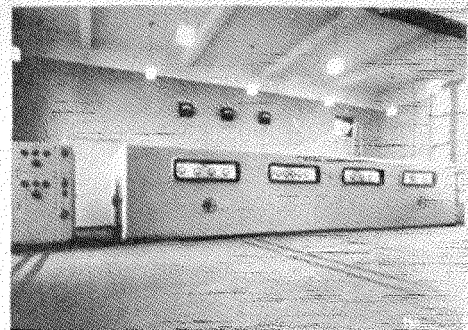

POWER AMPLIFIER UNIT

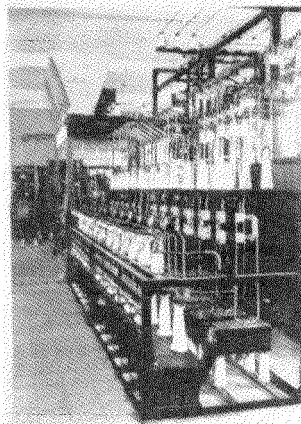

HOT CATHODE MERCURY VAPOUR
20,000 V. RECTIFIER

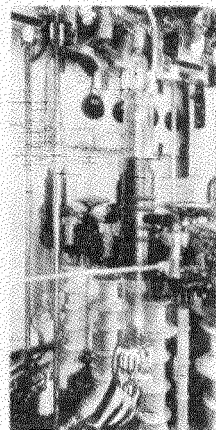

120 KW TUBE UNIT

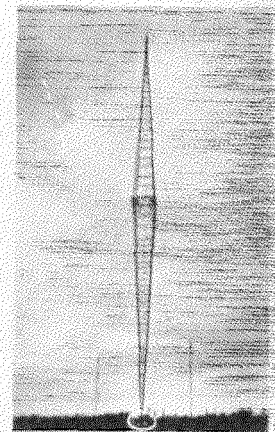

ANTENNA

BUDAPEST
120 KW
STATION

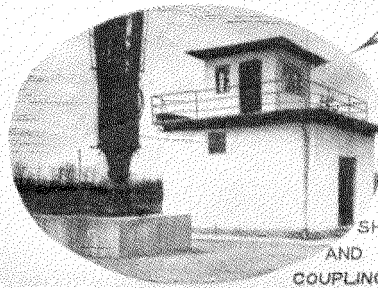

BASE OF ANTENNA
SHOWING INSULATORS
AND TRANSMISSION LINE
COUPLING STATION

Views of "Standard" 120 kw Broadcasting Station at Budapest.

place at low power with subsequent high frequency amplification.

The equipment was crystal controlled and yielded high quality reproduction with an overall power efficiency of the order of 22 percent.

(b) SOTTENS, SWITZERLAND

The Swiss Administration in 1930 decided to proceed with its plans for reorganizing its broadcasting service along modern lines. The system evolved gave listeners a greatly improved service including not only increased facilities for the interchange of programs amongst the principal cities of Switzerland, but also better reception through the installation of new transmitting equipment capable of meeting the highest standards then attained. Solution of the problem involved peculiar difficulties, partly because of the mountainous nature of the country.

The stations erected were intended to serve the French-speaking and German-speaking parts of the country. A third high power station to serve the Italian-speaking part of the country was deferred.

The first of the new high power stations (Sottens),^{78, 79} serving the French-speaking area, was inaugurated in March, 1931. The transmitter was designed to give carrier power into the antenna of 50 kw, which could be modulated 100 percent.

In January, 1935, the Swiss T.T. Administration placed an order to raise the power of the Sottens Transmitter to 100 kw and, also, to incorporate the latest broadcaster technique. In November, 1935, cutover of the entire extension was effected, the work of installation, adjustment and testing having been completed without interruption of the broadcasting service.⁸⁰

(c) BUDAPEST (HUNGARY) AND KALUNDBORG
(DENMARK)

The year 1933 witnessed extensive development of broadcasting services in Europe, and the International Standard Electric group of companies participated prominently by installing and putting into service eight new transmitters. The two largest, Budapest and Kalundborg, 120 kw and 60 kw, respectively, were described in 1934.³⁷ Both transmitters were built according to the

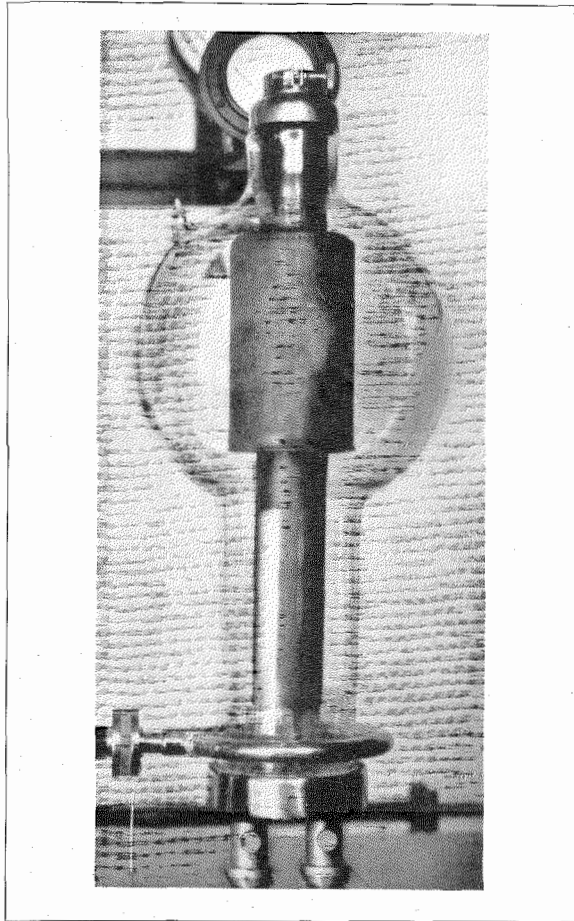

20,000 Volt, 250 kw, Hot Cathode Mercury Vapor Rectifier Tube—Kalundborg, 60 kw Transmitter.

same design, prepared by the I. T. & T. European Laboratories and were consequently very similar.

A distinctive feature of both stations was the form of construction of the power amplifier equipment. Following the practice commonly adopted in the installation of indoor high voltage power plant, this amplifier equipment was installed in cubicles.

Interesting features included the use of a small number of valves of high power in the last stage; high efficiency mercury vapor rectifiers for the high voltage d-c supply; and the elimination of rotating machinery except for the single filament machine and the water pumps by the utilization of dry metal rectifiers and hot cathode mercury vapor rectifiers for the low power supplies.

In the 60 kw transmitter, there was one 120 kw valve with a second in reserve on each side of the push-pull circuit. In the 120 kw transmitter, two

120 kw valves were in operation and two were held in reserve on each side of the circuit, i.e., four valves were in operation with each valve having a reserve associated with it.

(d) ANTENNAE

The longest wavelength for which an antenna of the anti-fading type had been constructed was 549.5 metres: the antenna operating in conjunction with the above-mentioned 120 kw transmitter at Lakihegy, near Budapest.³⁸ Its height was 307 m (1,005 ft.); it was higher than the Eiffel Tower and it was, therefore, the highest structure in Europe and the tallest mast in the world. From observations and reports received, it appeared that the limit at which fading became apparent had been extended from a distance of 120 km for the case of the old T antenna to a distance of between 180 and 200 km. This was equivalent to more than doubling the service area of the station.

(e) BRITISH EMPIRE

The provision of a broadcast service from the home country to the distant regions of the British

Empire for some years confronted the British Broadcasting Corporation with a problem of ever-increasing urgency.

Because of the distances involved, short wave working was necessary; the colonies and dominions, fortunately, could be divided into time zones: Australia (eight hours earlier than London); India (four hours earlier); Africa* (zero); and Canada (6 hours later).

This division necessitated separate treatment of each zone with concentration of radiation over selected areas. Important, also, was the use of different wavelengths for the various zones with due regard to special circumstances, such as broadcasts to Australia, the farthest away, in which case transmission must be effected through twilight conditions regardless of the path around the world selected. The aerial arrays, accordingly, were divided into five blocks, one for each zone, distributed around the transmitter building.

Due to the desirability of providing programs to the zones on alternative wavelengths, two transmitters were required with facilities for com-

* Two zones.

The British Broadcasting Corporation's Start Point Transmitter. The view on the right shows the transmitter hall from the gallery, with the transmitter (right), control desk (center), and modulation transformer and plate feed reactors (left). Pictured below is the vault beneath the transmitter hall with valve-cooling water pumps and high tension enclosure in the background.

The Start Point, South Devon, 100 kw transmitter (285.7 m) and also the 20 kw Clevedon, Somerset, transmitter (203.5 m) were inaugurated simultaneously on June 14, 1939. They employ class "B" modulation with negative feedback so that the total harmonic content amounts to not more than 2.5 percent at 90 percent modulation.

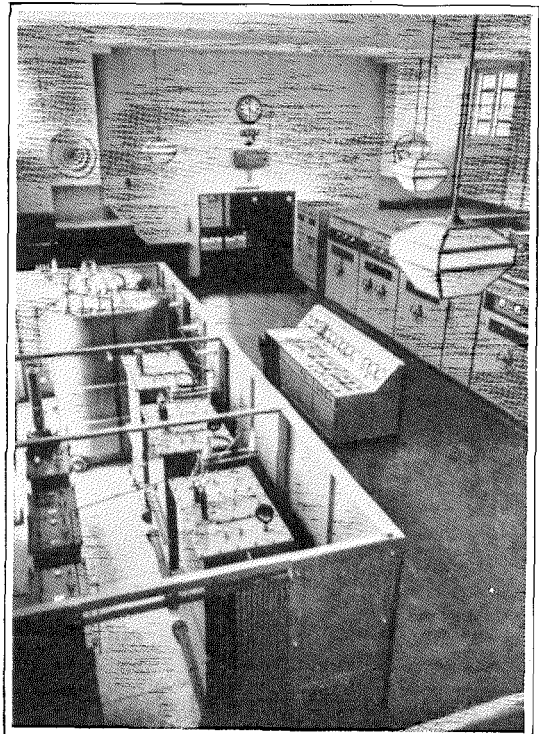
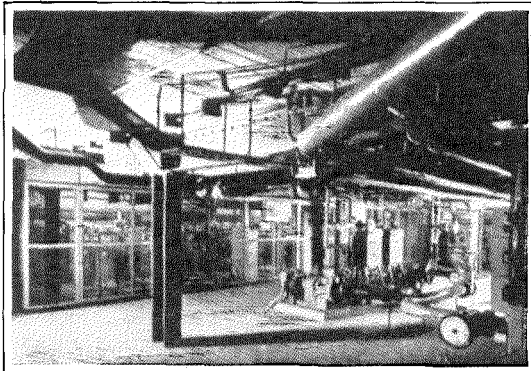

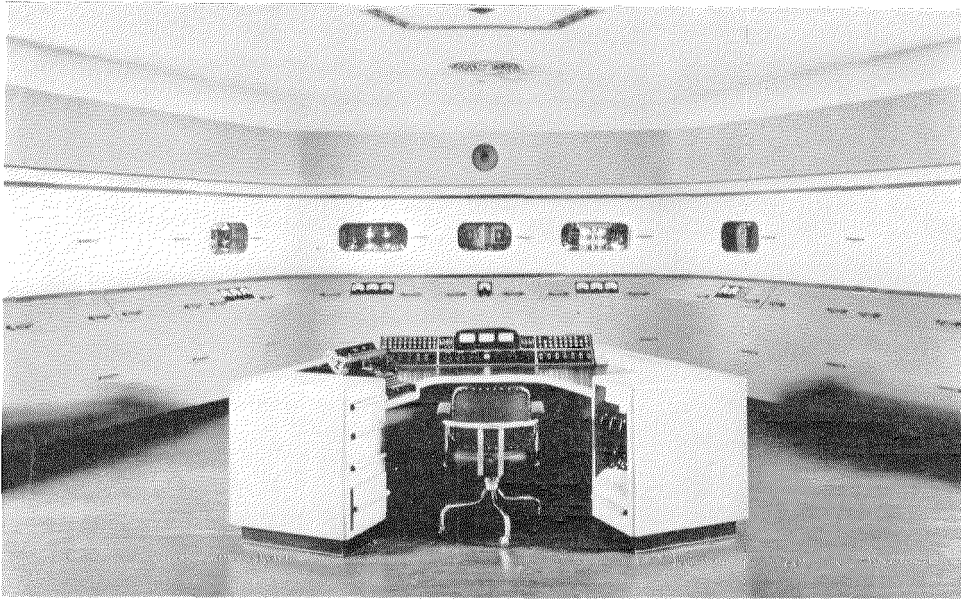

Control Room at Columbia Island (near New Rochelle, New York) of Columbia Broadcasting System's New Station WABC. The main 50 kw broadcast transmitter is back of the center panels and the auxiliary 5 kw transmitter is behind the adjoining panels at the right. The station was inaugurated on October 18, 1941; the equipment was designed and constructed to CBS specifications by the Federal Telegraph Company, a unit of the International Telephone & Radio Manufacturing Corporation.

plete interchangeability between them and all the aerial arrays. The transmitters had to be capable of working over the band 13 to approximately 50 metres and to include arrangements for quick wave change on any of the broadcast allocations in this band.⁸¹

Each transmitter was tuned to operate on any of six wavelengths between 16.9 and 50 metres, these six bands being especially reserved for short wave broadcasting. Transmitters were capable of giving unmodulated carrier power of 12 kw, which could be modulated to 95 percent without appreciable distortion, i.e., the strength of the audio frequency harmonics introduced into the modulation envelope was 30 db below the fundamental modulating tone.

Of the five units in which the transmitting apparatus was housed, the first unit of each transmitter contained four crystal oscillators. Any one of these could be switched on to the transmitter with which it normally worked or, if desired, to the other transmitter; hence, each transmitter could work on one of eight frequencies. Fre-

quency stability of these oscillators was approximately 40 parts to one million.

A moving ceremony, which evoked world-wide interest and in which communications played a unique rôle, took place in London on the 12th of May, 1937, in the Coronation of Their Majesties King George VI and Queen Elizabeth. From Broadcasting House the program was sent to the British Broadcasting Company's long and medium wave transmitters, used for the home service, and to the Empire short wave transmitters for broadcasting to the whole world. Radio facilities contributed by the I. T. & T. group of companies to this unique achievement included four B.B.C. Empire broadcast transmitters, two of which were specially expedited for use in the Coronation Ceremonies and were rated at 50 kw carrier power at 22 megacycles.^{39, 83}

Notable additions to the British Regional network were the medium wave transmitters at Stagshaw³⁹ and Start Point,⁸² supplied by Standard Telephones and Cables, Ltd., London. Both

are rated at 100 kw and employ class B modulation with negative feedback.

(f) NEW COLUMBIA BROADCASTING SYSTEM TRANSMITTERS

Uniquely located on a built-up island in Long Island Sound and providing optimum coverage of Metropolitan New York, the Columbia Broadcasting System's new 50 kw broadcasting transmitter, WABC, was inaugurated on October 18, 1941.⁸⁴ The illustration on page 155 shows a view of the control room.

Two new C.B.S. 50 kw international short wave transmitters, located at Brentwood, Long Island, were placed in service this year. They are being used in conjunction with specially designed directional antennae recently developed by the Mackay Radio and Telegraph Company for high efficiency beam service to South America and Europe (see Recent Telecommunications Developments section at the end of this issue).

(g) FINAL STAGE CLASS "B" MODULATION

As is evident from the preceding references, high power broadcasting in Europe developed fairly early due primarily to national rivalry; the power of broadcasting stations tended to increase progressively and was restricted only by technical limitations. Under those conditions the application of final stage Class "B" modulation proved especially useful and it was embodied in a number of transmitters prior to 1938; examples are transmitters at Melnik, Czechoslovakia, and at Stagshaw, England.

In April, 1938,⁸⁵ the performance of the Class "B" system was analyzed with particular reference to efficiency and fidelity. Mention was made of application to short wave transmitters where this system is particularly advantageous in comparison with alternative methods because of the wide flexibility which may be allowed in the adjustment of the high frequency stages. The problem of rapid wave change is greatly simplified by avoiding the necessity of critical adjustment of drive levels.

(h) 120 KW VACUUM TUBE

Rapid increase in high power broadcasting stations prior to 1933—certain stations radiating carrier power of 120 kw and reaching a peak

power in the antennae of 480 kw with 100 percent modulation—prompted development and application of a 120 kw vacuum tube.⁸⁶ Experience had shown that the number of tubes, say of 40 kw capacity each, that could be used in parallel was limited and was attended with many difficulties, particularly the "Rocky Point Effect."

The tube developed possessed the following characteristics:

Heating power.....	5.4 kw
d-c anode voltage.....	20,000 volts
Maximum H.F. power as oscillator at 70% efficiency with $E_B=20,000$ volts.....	= 120 kw

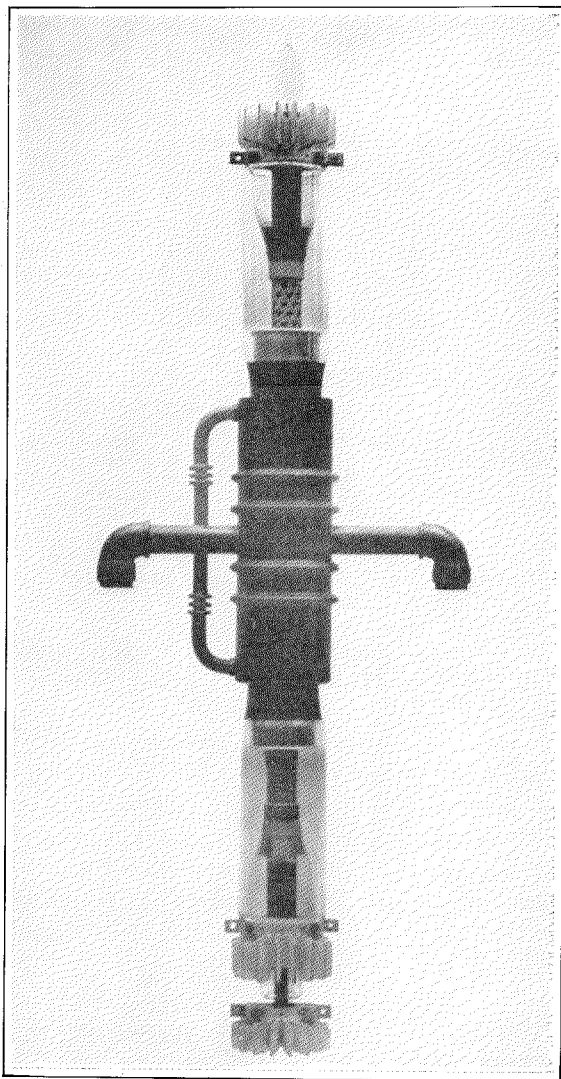

120 kw Vacuum Tube (1933). Four such tubes in parallel in a broadcaster would absorb an average power of 750 kw and give a carrier wave power of at least 250 kw and a peak power of 1,000 kw.

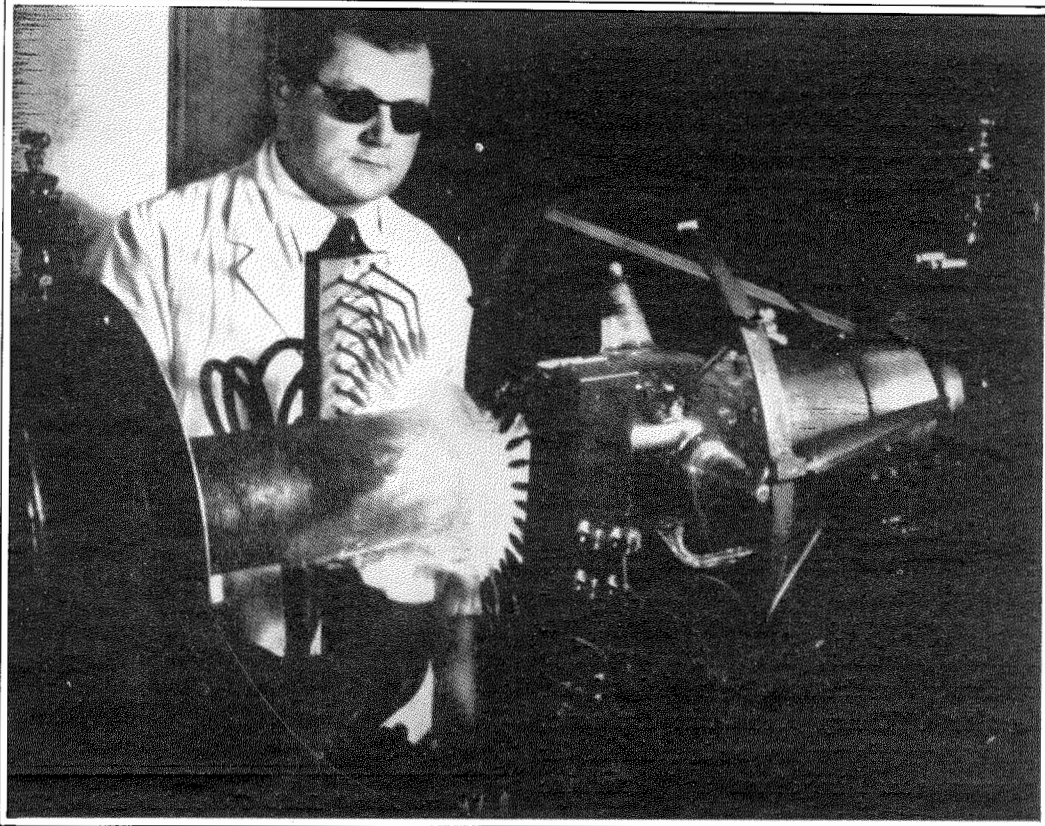

Making the Glass-to-Metal Anode Seal on a 200 kw Vacuum Tube.

H.F. output power on test as oscillator at 70% efficiency with $E_B=25,000$ volts	= 200 kw
Carrier wave power as linear amplifier, 100% modulation at 20,000 volts	30 kw
Probable filament life	6,000 hours

The development work showed that it seemed quite possible to develop and manufacture a satisfactory 200 kw tube. This, incidentally, has been accomplished and such tubes are now being manufactured by Standard Telephones and Cables, London, with the following characteristics:

Filament power	18 kw
Plate voltage as modulating amplifier	13,000 volts
Peak power per tube	400 kw

(i) HOT CATHODE MERCURY VAPOR HIGH TENSION RECTIFIER

Due to the construction of higher power transmitters, the problem of providing efficient and

reliable power equipment became more pressing. In October, 1936,⁸⁷ an important article was published, dealing with the respective characteristics and performance of the various types of high voltage d-c supplies for high power radio transmitters and making comparisons with hot cathode mercury vapor rectifiers. Characteristics of a series of hot cathode mercury vapor valves designed by L.M.T. Laboratories (Paris) were cited and the influence of the rectifier circuit characteristics was considered.

Subsequent developments showed that the description of a simple system for firing grid-controlled, hot cathode mercury vapor rectifiers was especially significant.

(j) STUDIO SYSTEMS

Following improvements effected in the transmission qualities of telephone cable systems, the

policy of partial or complete centralization of studios was adopted rather generally in Europe. An outstanding example of such centralization is the studio system of the Belgian Institute National of Radiodiffusion (I.N.R.) at Brussels, supplied by the Bell Telephone Manufacturing Company and inaugurated in 1938. The system, then at least, was the largest center in existence anywhere for the production of broadcast programs.⁸⁸

The installation included separate amplifier groups and control desks for seventeen studios, two dramatic mixer positions and five recording rooms, and, concentrated in a central control room, large banks of amplifiers for broadcast and monitoring purposes. Connections of the various studios to the outgoing line positions serving the stations for the French and Flemish zones of Belgium and the short wave station for the Belgian Congo, as well as to the dramatic mixer positions and recording rooms, were made through a step-by-step automatic equipment. Facilities for connections to about 200 monitor positions throughout the building were furnished by means of a Rotary Automatic exchange. Both automatic equipments were interlinked for checking purposes. Fire alarm and extensive signaling systems also were included in the installation.

Mobile Communications

(a) SHIP-AND-SHORE TERMINAL TELEPHONE EQUIPMENT

Commercial radiotelephony between Europe and America naturally directed endeavors towards the solution of the problem of maintaining telephone communications with the larger passenger vessels on the Atlantic route.

After referring to successful tests made between the International Telephone and Telegraph Laboratories and the SS *Berengaria*, Colonel A. S. Angwin (1930) mentioned an agreement to undertake a full scale experimental trial between the British Post Office and the International Marine Radio Company (an I.T. & T. associate). From these trials, commercial ship-shore service resulted; service to the SS *Majestic* was opened in February, 1930 (at first only for incoming calls).

Colonel Angwin indicated some of the special



"Queen Mary" Radio Transmitter Room, Showing the Transmitters Remotely Controlled from the Radio Operating Room 400 Feet Away.

problems confronting the British Post Office, discussed choice of frequency and considered antenna arrays, the transmitter at the Rugby Station, the Baldock Receiving Station, land line connections, the prevention of singing, etc.⁴⁰

(b) MOBILE RADIOTELEPHONY— A REVIEW (1932)

An interesting article⁴¹ reviewed in general terms two-way radiotelephony on larger passenger vessels and smaller ships, including development, technical features and results obtained. Perhaps the earliest demonstration of marine two-way telephony was given in 1915 by Bell System engineers in connection with the U. S. Warship, *New Hampshire*. Following the development of short wave radio, telephony to and from ships became more practical and in 1929, short wave experiments were begun. Service on the British ship, *Majestic*, and on the American ship, *Leviathan*, was inaugurated early

in 1930. These were followed by the *Olympic*, *Homeric*, *Belgenland*, *Empress of Britain* and *Monarch of Bermuda*. All were equipped with elaborate transmitting, receiving and voice frequency equipment, giving duplex service from a telephone booth or cabin on board the vessel.

Remarkable results were obtained over extremely long distances during the world cruise of the *Belgenland* in the winter of 1930-31 and the *Empress of Britain* in 1931-32. Successful conversations were held with London when the ships were in the China Sea and with New York when at Alexandria.

With the object of reducing the number of necessary frequencies and simplifying apparatus,

the International Telephone and Telegraph Laboratories conducted experiments in which the *SS Olympic* transmitted and received on the same frequency. Voice operated devices were used instead of the manually operated switch ordinarily employed on single wavelength systems.

Two-way telephonic communication to airplanes, in Europe and in the United States, also was considered, as was radiotelephony to trains.

(c) CUNARD WHITE-STAR R.M.S. QUEEN MARY RADIO INSTALLATION

The *Queen Mary* installation, undoubtedly, is the largest and the most complete in the history of marine radio and was engineered to meet all

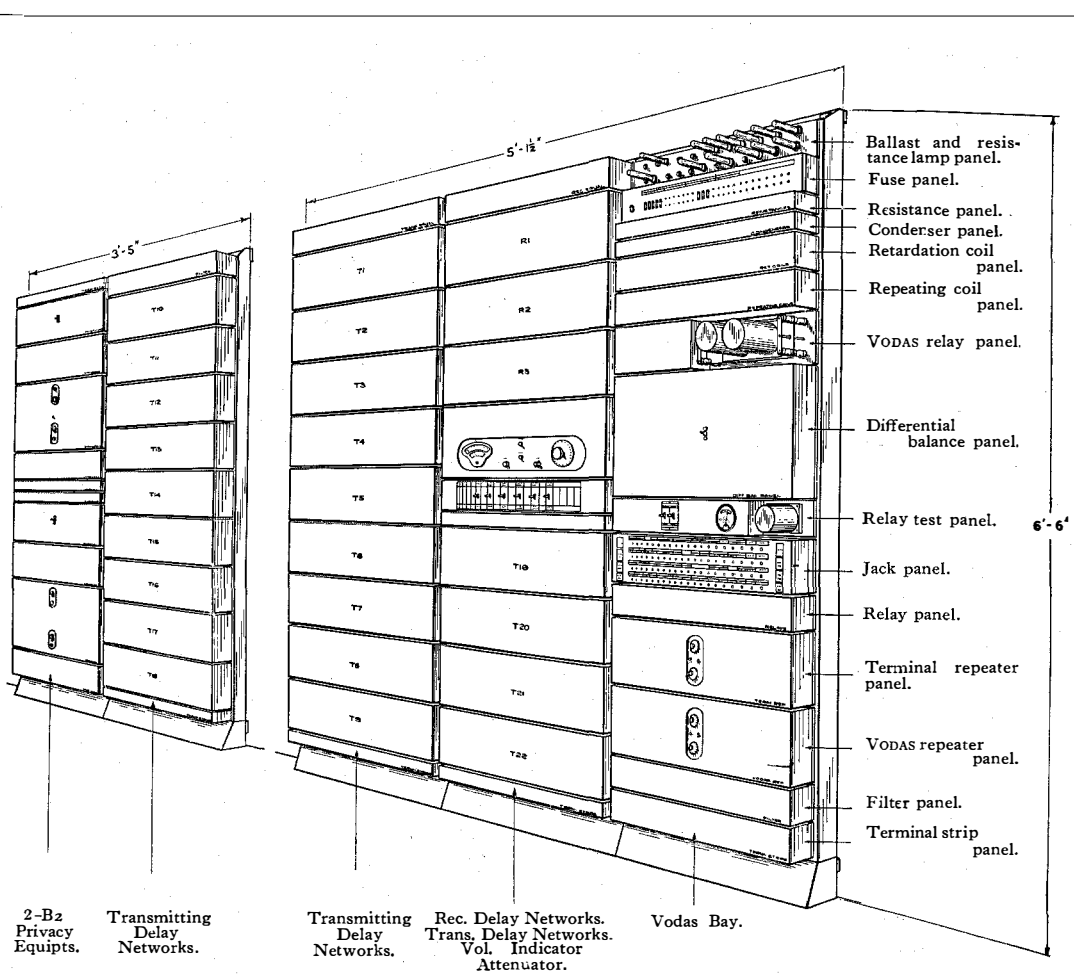

"Queen Mary" Rack Assembly of Terminating Equipment. Its primary function is to prevent local interaction between the radio transmitter and radio receiver, despite their being deliberately coupled together through the subscriber apparatus and also unavoidably coupled together by induction from aerial to aerial.

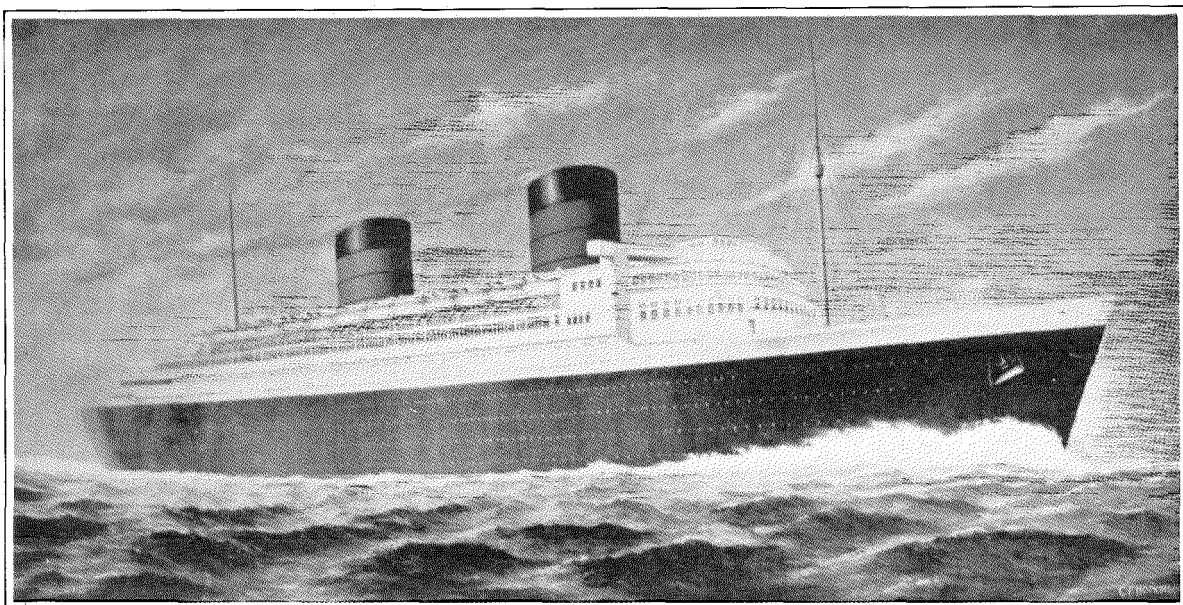

"Queen Elizabeth." As in the case of the "Queen Mary," her radiotelegraph, radiotelephone and associated equipment were to be supplied and operated by the International Marine Radio Company, Ltd., London.

commercial telephone and telegraph traffic requirements, in addition to the usual navigational and safety services. Many recent advances in radio technique were embodied in the design of the radio system and several features previously



Marine Radio Unit for Cargo Vessels. Developed by the Federal Telegraph Company.

associated only with land stations were applied for the first time to a marine radio installation.^{89, 90}

On the maiden voyage, the heavy simultaneous demands made by telegraphy, telephony and broadcasting kept the four transmitters and at least four of the receivers in continuous operation for the greater part of the time the ship was at sea. Radiotelephone calls were completed from passengers' cabins to points as far distant as Capetown and Johannesburg, South Africa.

A complete voice operated switching device, the so-called V O D A S, made it possible for a passenger to talk on the radiotelephone circuits from any one of the 500 telephones of the ship's two-wire telephone exchange, even under the most difficult radio conditions. Conversations could be carried on simultaneously with Europe or America; or, alternatively, the two independent circuits could be diverted to Europe or America.

The *Queen Mary* utilized 32 different wavelengths or frequencies. Her four main transmitters were on dial control direct from the operating positions located 400 feet from the transmitter room; change of frequency was accomplished automatically by means of a telephone dial. Complete secrecy of telephone conversations against the casual "eavesdropper"

was assured through the inclusion of the frequency "wobbler."

The *Queen Mary* radio equipment was almost entirely manufactured by I. T. & T. associate companies, and was supplied, installed and operated by the International Marine Radio Company, Ltd., under contractual agreement with the Cunard White-Star, Ltd.

As in the case of the *Queen Mary*, it is pertinent to note that arrangements also were completed (1938) for the supply and operation by the International Marine Radio Company, Ltd., London, of the *Queen Elizabeth* radiotelegraph, radiotelephone and associated equipments.⁹¹

(d) NEW MARINE RADIO UNIT FOR CARGO VESSELS (1941)

A recent development of the Federal Telegraph Company, a unit of the International Telephone and Radio Manufacturing Corporation, provides all necessary facilities for safety and communication purposes and combines, in a single compact cabinet, equipment which ordinarily comprises as many as twelve separate units. Installation is greatly simplified inasmuch as the unit is prac-

tically ready to "plug in" for power supply and antenna connection.⁹²

Aerial Navigation

(a) AUTOMATIC RADIO COMPASS

To extend in a simple way the effective visible horizon of an aircraft pilot, Le Matériel Téléphonique, Paris, in 1934, developed and constructed an automatic radio compass, which was the first automatic direction finder with 360° indication ever installed on board an airplane. The apparatus in principle is based on a receiving loop rotating at constant velocity around a vertical axis, permitting maximum reception each time the plane of the loop is oriented towards the transmitter.⁴²

In France, both civil and military authorities submitted this radio compass to exhaustive tests and many airplanes were equipped with it. Actual service results were highly satisfactory and its use prior to the outbreak of the war in Europe was being extended not only in France but also in other countries, including Spain, Norway and Czechoslovakia. As mentioned above under In-

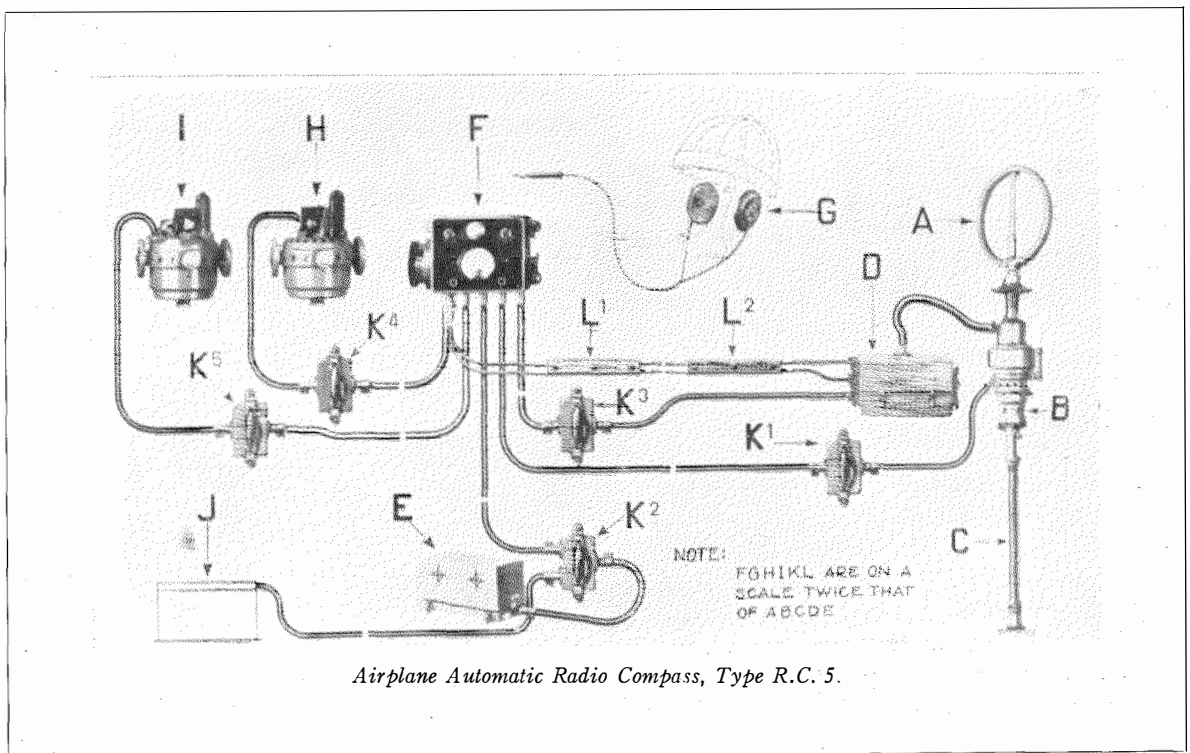

Airplane Automatic Radio Compass, Type R.C. 5.

production, this compass was introduced in the United States in 1937.

Combined with other instruments ordinarily carried in a plane, the automatic radio compass also was found useful for determination of drift, landing during bad visibility, etc.

(b) NIGHT ERROR AND MOUNTAIN EFFECTS IN AERIAL NAVIGATION

The important phenomena of Night Error, Mountain and Polarization Effects in aerial navigation have been quite exhaustively studied by companies in the I.T. & T. group both in Europe and in the U. S. A.

In addition to the phenomena themselves, precautionary and corrective measures have been considered and procedures in airplane navigation with the radio compass and other devices discussed. A medium wave Adcock direction finder for airdromes, free from polarization error to a large extent, has been developed and installed in many places all over Europe. A semi-portable direction finder with an Adcock aerial system also has been briefly described.^{43,44}

(c) INSTRUMENT LANDING OF AIRPLANES

In view of the fundamental importance of the problem of landing airplanes under adverse weather conditions, International Telephone and Telegraph companies for some years have studied the problem of instrument landing. Their instrument landing equipment was installed at the Indianapolis Airport in 1938 for demonstration purposes. Modifications to meet specific requirements were introduced and, in July, 1940, an initial order was placed with the International Telephone Development Company (now the International Telephone & Radio Manufacturing Corporation) by the Civil Aeronautics Administration. This system, variously designated as the C.A.A., Indianapolis or International Telephone and Telegraph Instrument Landing System⁴⁵ provides the pilot with complete guidance to the airport runway, both horizontally and vertically. Through beams of ultra-short wave energy transmitted from highly directive equipment at the airport, the pilot by means of a conveniently placed instrument on his instrument panel is provided not only with the exact line of approach laterally to the con-

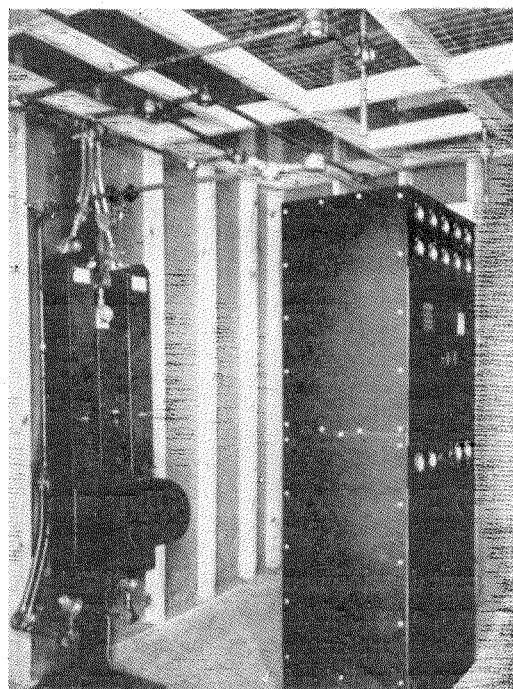

Instrument Landing of Airplanes. Interior of localizer building, showing transmitter and mechanical modulator.

crete runway but also with the exact line of descent, when five miles or more away, to the runway so that the airplane settles upon the latter as in normal landing. Further, two "marker beacons" are provided along the line of approach to the landing runway: one indicates to the pilot arrival at a certain point, some distance from the runway, when he should be at a prescribed altitude and in line with the instrument landing apparatus so as to be headed directly for the runway; the other informs the pilot when he passes the boundary of the airport. With these facilities, pilots can land with consistent safety even when weather conditions are extremely difficult.

(d) ULTRA-HIGH FREQUENCY LOOP ANTENNAE

The antennae considered were developed for two applications:

1. As elements in radiating systems of localizers and radio ranges used to guide aircraft;
2. As receiving antennae carried by aircraft.⁴⁸

The unique property making them useful is that they radiate only horizontally polarized waves. Their directional characteristics are simi-

lar to those of a vertical dipole except that the waves emitted are horizontally rather than vertically polarized.

After calculation of the magnetic field of one radiator and of the four radiators forming the loop, as well as the radiation resistance, three types of ultra-high frequency loop antennae are described. Gain of loop antennae and radiation efficiency are discussed and applications of the three types cited. Methods of measuring radiation resistance also are indicated.

(e) AIRPORT COMMUNICATIONS AND AIRPORT ILLUMINATION

For what is perhaps the only comprehensive outline of the principal communications requirements of an airport and a description of some of the most modern equipment evolved to date, reference may be made to a recently published article. It deals primarily with LaGuardia Field, the Municipal Airport of the City of New York.⁴⁶



Special Coaxial Cable Connecting the Eiffel Tower Television Transmitter with the Aerial at the Top of the Tower. The cable met rigid frequency characteristic and low attenuation loss requirements; it spanned the distance of over 380 metres between the transmitter and the aerial and weighed 12 tons.

An interesting airport illumination installation in Argentina has been described recently.⁹³

Television

In March, 1937, Le Matériel Téléphonique, Paris, received an order for the realization of a 30 kw peak power television transmitter to be installed at the foot of the Eiffel Tower. The transmitter was placed in service December 25, 1938 and was then, and probably still is, the highest powered television transmitter in the world.²⁵

The carrier frequency of the transmitter was 46 mc/s. Both sidebands were used, extending to 3 mc/s each side of the carrier frequency. The polarity of transmission was positive, i.e., a white image raised the transmitter power to the peak value, which was actually 35 kw (nominally 30 kw). The vision antenna surrounded the top portion of the tower for a few metres below the flag pole; the sound antenna was placed at the top of the flag pole.

The French television standard, which was to remain in force up to July, 1941, called for 25 complete pictures per second, each picture containing between 440 and 455 total lines, the lines being interlaced so that the frame and flicker frequency was 50 per second.

The design of the output stage of the Eiffel Tower television transmitter is described elsewhere in this issue of *Electrical Communication*.

Public Address Systems

(a) LIVERPOOL CATHEDRAL

In the history of the Church of England, the opening of the Liverpool Cathedral was an important event; for, since the Reformation in the 16th Century, it was the first Anglican Cathedral Church to be constructed in the Northern Ecclesiastical Province. Liverpool Cathedral was planned to be the largest church in England; the portions opened in 1924 consisted of the East End, comprising Sanctuary and Choir, and the North and South Transepts. Some conception of the magnitude of this structure may be obtained from the illustration on page 164 when it is considered that the seemingly small electric light pendants are actually twelve feet in height and seven feet six inches in diameter.

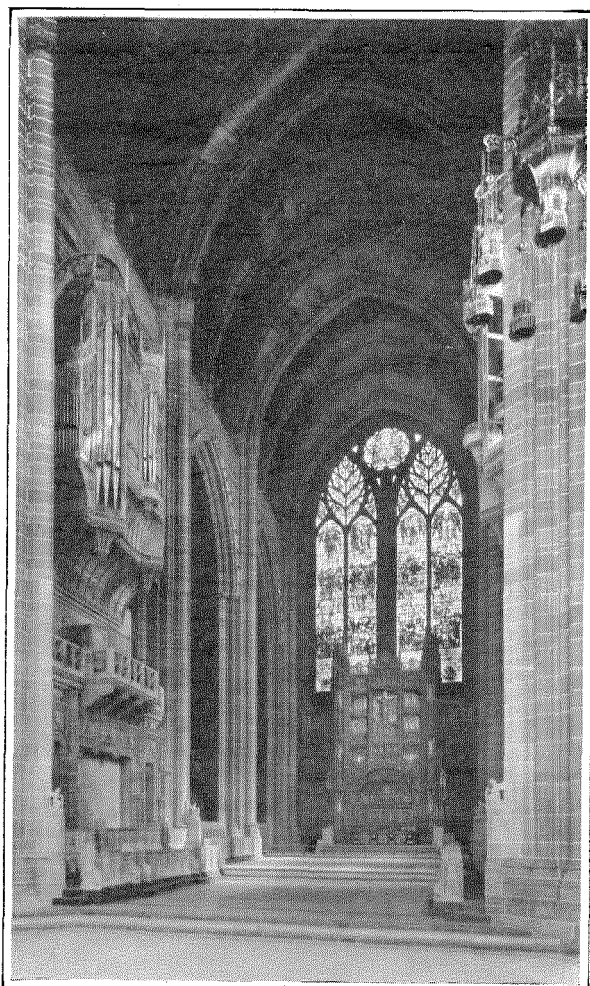

Liverpool Cathedral: The Choir, Looking East. For the purposes of the Consecration Ceremony, loud-speaking projectors were mounted in the electric light pendants which are 12 ft. in height and 7½ ft. in diameter.

As a result of the success of the public address system in amplifying the address given by the Archbishop of York at the Consecration Ceremony, the Bishop of Liverpool decided that it would be necessary to have it installed in the Cathedral as a permanent fixture.⁹⁴

The Cathedral has massive columns, marble floors and stone walls; some of the stones measure 5 ft. X 5 ft. X 4 ft. and weigh over three tons. Aside from the acoustical and other engineering problems that required solution, it will be appreciated that the installation of an invisible cabling system in a finished structure of this type was no easy task.

(b) 31ST INTERNATIONAL EUCHARISTIC CONGRESS, DUBLIN, JUNE, 1932

Preliminary investigations, equipment arrangements and results obtained with the vast, high quality public address system at Dublin in June, 1932, were described in April, 1933.⁹⁵ At the Pontifical High Mass on the closing day of the Congress, the congregation numbered approximately one million and occupied an area of about 200 acres. The equipment included street systems for reproducing speech and music over processional routes covering a distance of fifteen miles.

(c) 32D INTERNATIONAL EUCHARISTIC CONGRESS, BUENOS AIRES, OCTOBER, 1934

"Most comprehensively international of any biennial gathering of world Catholicism was the Thirty-Second International Eucharistic Congress held in Buenos Aires, October 10-14, 1934. This statement is made without reference to considerations other than the vast geographical proportions of the congregation which, unrestricted to local confines, listened to features of the program by virtue of the wire and radio facilities of the International Telephone and Telegraph group of companies and connecting services utilized for the transmission of words and music. Listeners included not only the multitude in actual attendance at the Congress but also, by means of an intercontinental broadcast hook-up, countless millions throughout South and North America, Europe, and other parts of the globe."⁹⁶

(d) 34TH INTERNATIONAL EUCHARISTIC CONGRESS, BUDAPEST, MAY, 1938

A prominent Congress feature was the Boat Procession of the Holy Eucharist on the Danube when public address systems arrayed on both banks of the river transmitted the programs to the crowds aligned on its shores in devout adoration.

The Eucharistic Congress sound system, including all equipment and apparatus components utilized, was of impressively high quality and admirably adapted to the requirements imposed.⁹⁷

(e) THE 1937 PARIS EXHIBITION

Original dispositions of public address systems were devised at the Paris 1937 Exhibition where loudspeakers were installed on eleven pontoons moored in the Seine and where music in combination with water, light and smoke added to the superlative esthetic effect of the Fêtes de la Seine.^{97a} For its many contributions to the Paris Exhibition, including novel demonstration equipments and automatic attendance recording devices actuated by means of photoelectric cells, official awards were made to Le Matériel Téléphonique.

Machine Switching*(a) PARIS AREA*

Study of the Paris telephone requirements started about a year before World War I and was resumed in 1924 or the early part of 1925. The unavoidable delay, however, gave the Administration the opportunity to study the methods and systems adopted by other administrations and to profit by their experience.

The French Government appointed two committees, one technical and the other general, to

study the telephone requirements of Paris. After exhaustive explorations, the two committees unanimously chose the Rotary System for Paris, and, in October, 1926, the contract for the first four offices was awarded to Le Matériel Téléphonique. The contract carried with it the proviso that standard Rotary apparatus should be used throughout; also that the circuits should be designed by Le Matériel Téléphonique, and that the full responsibility for the successful operation of the system should rest with that company. The automatic system was planned to care for the city and the surrounding suburban areas with possible ultimate extension.⁴⁹

On September, 22, 1928, Rotary Automatic was introduced into Paris by the cutting over of the Carnot office with 3,500 working lines.

The trunking plans of the Paris Network during the transition stage from manual to automatic working were described in 1934. To quote from the article:⁵⁰

“To sum up, one can say that, bearing in mind the experience gained with thirty-two cut-overs, up to date, the semi-automatic trunking plans utilized in Paris and suburban offices, in the transition stage between manual and full



Thirty-First International Eucharistic Congress, Dublin, June, 1932—O'Connell Bridge Altar and Part of Street Area Catered to by Public Address System.

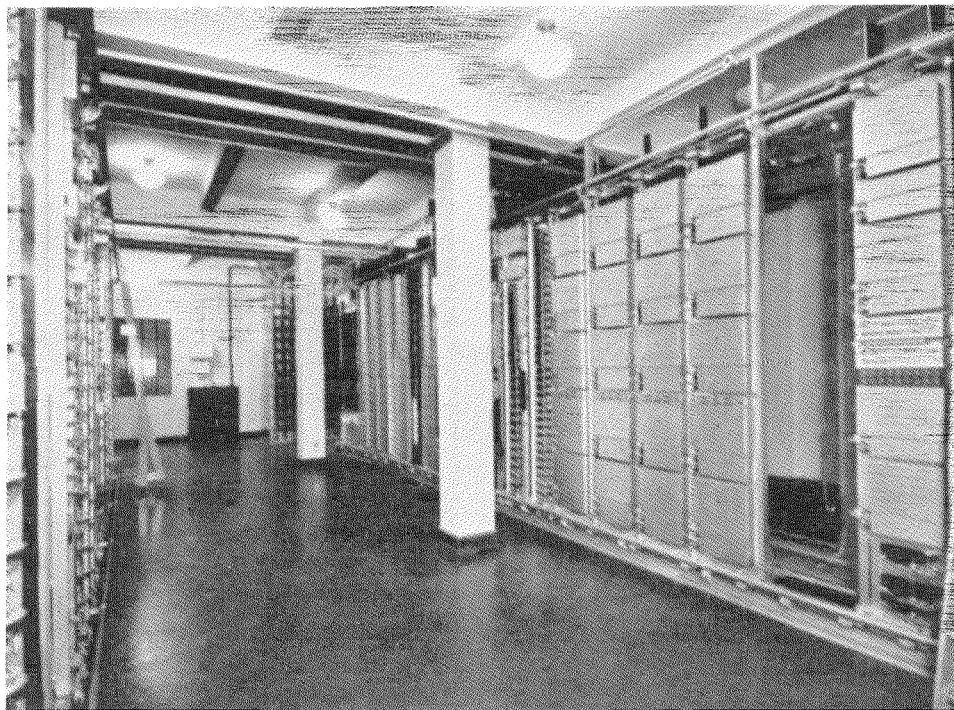

7A-2 Rotary Equipment in the Callao Exchange, Compañía Peruana de Teléfonos Limitada, Lima, Peru.

automatic operation, have enabled the progressive conversion to automatic of the network without undue disturbance to the public, and also have improved the service in the offices where they are temporarily installed.

"From the economic standpoint, it is important to note that the gradual conversion of such an important telephone area has been accomplished without extensive modifications to the existing cable network due to application of the translator-registers associated with the equipments mentioned."

The conversion of the Paris City and Suburban areas was completed prior to the outbreak of the present war, and transformation of the Regional area had been progressing in all directions. Abnormal conditions prevented descriptive publications in English; the interested reader, however, is referred to articles which appeared in *Annales des Postes Télégraphes et Téléphones*: "Transformation en Automatique de la Région de Paris," by André Duprez, June, 1938; "Adap-

tation du Réseau Téléphonique de Paris à L'Exploitation Automatique de la Région de Paris," by André Blanchard, July 1938.

(b) ROTARY AUTOMATIC IN SWITZERLAND

In January, 1930, the last manual office in Geneva was replaced by an automatic office of the Rotary type, thereby placing Geneva with Zurich on an all automatic basis. In Basle, the banking center of Switzerland, Rotary Automatic equipment also was installed.^{51, 52, 53}

Unusually interesting and highly satisfactory data involving service observations and maintenance results obtained by the Swiss Administration with Rotary Automatic equipment were published in 1931.⁵³ In the following decade, the progressive Swiss Administration greatly extended its network and installed the latest types of Rotary equipment so that similar data brought up to date doubtless would show even more favorable results.

Based on its experience with automatic operation both in city and rural services, the Swiss Administration undertook consideration of the automatization of the toll service. It is notable that the first step in the automatization of the toll plant, between the cities of Berne and Biel, was completed in 1930.⁵⁴

The second stage was completed by the introduction in Basle of automatic toll service in 1933. A series of new features and operating methods, not previously utilized, were introduced; the equipment employed was the 7D Rotary System.

Subscribers had the choice of establishing their own connections by means of the telephone dial or to request a toll connection from the operator. Their quick recognition of the advantages of direct automatic selection was demonstrated by the fact that, within a few months after the introduction of the new system, 85 percent of all connections were thus established (Basle-Zurich and vice versa).

Metering also was accomplished automatically in accordance with prescribed zone charges and elapsed time.

(c) NATIONAL DIALING IN THE NETHERLANDS

The Netherlands Government Telephone Administration in collaboration with the municipal networks of Amsterdam, Rotterdam, and The Hague, prior to the invasion of Holland in 1940, had been carrying out a vast program of automatization of its telephone plant. Plans included the conversion to automatic operation of all manually operated local exchanges and the installation of equipment for handling long distance traffic on an automatic basis. Approximately 1,200 exchanges were involved.

On January 1, 1938, subscribers who were able to handle their calls on an automatic basis constituted 70 percent of the total number of lines connected in Holland. Exchange networks also had been grouped and cable plant provided to correspond with the division of the country into twenty rural districts or zones in line with long distance traffic requirements.⁵⁵

Dialing service from the whole of the Haarlem Zone towards the Amsterdam Zone was inaugurated over 24 toll lines on July 1, 1937. Shortly thereafter, it was necessary to increase these toll lines from 24 to 30 due to stimulation of traffic

through the provision of automatic facilities. Opening of the automatic service from the Amsterdam Zone to the Haarlem Zone occurred on February 28, 1938.

(d) SIGNALING SYSTEMS ON TOLL LINES

Introduction of full automatic equipment in rural and suburban exchanges and the rapid progress in Europe of subscriber-to-subscriber toll dialing necessitated a departure from the familiar methods of direct current signaling in use in local telephony.

A new type of 50-cycle signaling system was developed by the Laboratories of the Bell Telephone Manufacturing Company, Antwerp, with low sending voltage and current. Early in 1936 a complete demonstration of the Rotary Automatic Toll System was made in Berne for officials of the Swiss P.T.T.; the demonstration equipment subsequently was installed in Zurich, Lugano and Faido* in order to test the 50-cycle signaling system under service conditions.⁵⁶

The trial included:

- (a) An outgoing toll exchange: Faido;
- (b) A tandem toll exchange: Lugano;
- (c) A second tandem toll exchange: Zurich;
- (d) A terminating toll exchange: Zurich;
- (e) A local automatic exchange;
- (f) Six standard 2-wire repeaters.

Faults encountered were not greater than in the average local network.

International voice frequency signaling and dialing in Europe, because of its special importance in the interconnection of national communication systems, was a problem to which the C.C.I.F. had been devoting considerable attention prior to the outbreak of war in 1939. The development aspects involved were rather exhaustively discussed in this journal in July, 1939. Summarization here cannot be attempted because of the complexity of the subject; listing of the contents of the article⁵⁷ may be of interest.

1. Introduction.
2. Importance and Necessity of Voice Frequency Signaling.
3. Comparison with d-c and other a-c Signaling Systems.

* Zurich is in the northern part of Switzerland; Lugano near the southeast border; Faido is at an intermediate point.

4. Interference between Voice Frequency Systems.
 5. Recommendations to Avoid Interference between Voice Frequency Systems.
 6. Time Variations Associated with Voice Frequency Signals.
 7. Choice of Frequency for the Prefix Signal.
 8. Voice Immunity Tests.
 9. Determination of Length of Prefix.
 10. Efficiency of the Guard Circuit.
 11. Considerations Controlling the General Arrangement of the Voice Frequency Code of Signals.
 12. Signal Code Timing.
 13. Transit Working.
 14. Summary of Research Work in Progress and Questions Awaiting Consideration.
- Appendix No. 1—Glossary of Terms.
 Appendix No. 2—Translation of Proceedings of 3d Commission of Rapporteurs, Oslo, June 1938.
 Bibliography.

(e) 7A-2 ROTARY AUTOMATIC
TELEPHONE SYSTEM

The cutover of 12,000 lines of the new 7A-2 Rotary equipment in Bucharest, Rumania, in 1933, marked the completion of an extensive program calling for the complete redesign of the 7A Rotary System. The following résumé conveys an idea of the new features and the extent of the changes introduced.^{58, 59, 60}

Apparatus and Equipment

1. A redesigned line finder, selector and sequence switch, together with associated mounting bays, permit a substantial saving in space occupied, lower manufacturing costs and reduced maintenance expense.
2. New manufacturing processes make the characteristic Rotary construction features more robust, and new finishes make both apparatus and wiring more impervious to humid atmospheric conditions such as obtain in tropical climates; an improved method of shielding also is used to serve for fire protection, together with a new type of switchboard wire which possesses greatly improved fire resisting qualities.
3. Radically improved methods for fusing and power distribution greatly facilitate maintenance and reduce first costs. To these same ends the tone and alarm distribution systems have been modified.
4. A new style of switchrack construction permits of considerable saving in space without sacrifice of rigidity which has always been a feature of the Rotary system.

Switching System Facilities and Circuits

1. While the new switches and circuits are considerably changed, the requirement that they must interwork with existing networks with a minimum amount of change was constantly kept in mind. As a result, extensions to present offices and networks can be made as readily as though the present system were continued in use.
2. Improvements have been made in the new circuits and apparatus regarding operating times and limits, voltage range and other similar factors with the result that the operating ability of the Rotary equipment has been further improved. A notable change of this type is the new selector commutator which produces an unusually uniform impulse and should require practically no maintenance.
3. The new switching scheme employed for the line finder makes use of a new 200 point switch together with special alternative outlets for completing overflow traffic during the peak load periods. Another important switching change has been made between the cord and register circuits, permitting considerable saving in equipment costs.
4. Provision is made in the selector switches to provide for converting two adjacent levels into one common group of trunks. This feature raises the number of trunks in one common group from the previous figure of 30 trunks to a new maximum of 60 trunks which should be more than sufficient for present or future requirements.
5. In redesigning the system, full recognition was given to the present tendency towards long distance dialing, CLR and other special toll services, together with the increasing demand for simplified facilities for interworking with rural and suburban automatic networks. Provision has also been made for connecting with other types of automatic systems and manual exchanges with a minimum amount of expense.
6. Time, zone and multi-metering features have been developed as an integral part of the system and can be applied to all conditions.
7. Miscellaneous service features, such as paystations, party lines (with or without metering), direct working with apartment house satellites, and other similar arrangements can be provided to meet all requirements.
8. Traffic recording and maintenance which already are noteworthy features of the Rotary system have been further simplified. Included in these improvements are centralized service observing and special facilities for the detection of malicious calls, automatic faulty line indication and delayed back release.

(f) 7D ROTARY AUTOMATIC
TELEPHONE SYSTEM

By 1935 the Rotary System had been installed in many of the principal cities of Europe: Oslo, Copenhagen, The Hague, Brussels, Antwerp, Liège, Paris, Zurich, Basle, Geneva, Madrid,

Barcelona, Bucharest and as far afield as Istanbul, Cairo, Shanghai, Rio de Janeiro, Lima and Mexico City. In round figures, 1,621,000 lines had been provided (now well over 2,000,000) in 23 different countries and in 642 different exchanges.

A comprehensive redesign of the equipment intended for use in small communities was described in 1935.⁶¹ Among many other features, it included means for the automatic interconnection over a wide area of subscribers in small communities. The largest rural area served by the 7D Rotary System was situated in the neighborhood of Zurich and comprised 50 offices with a total of 14,800 lines. This area worked on a full automatic basis with the 7A Rotary multi-office area of the city of Zurich. The complete Zurich district thus comprised approximately 60,000 subscribers' lines interconnecting on a full automatic basis. Subscriber-to-subscriber dialing between Basle and Zurich being in operation, plans

for early extension to rural subscribers had been completed (April, 1935). Their realization provided for the full automatic interconnection of over 100,000 lines of Rotary equipment installed in 124 different exchanges, the two most distant being separated by 100 km; the area covered more than 1,500 square kilometres.

Automatic Ticketing of Telephone Toll Calls

A new telephone facility known as Automatic Toll Ticketing, the first of its kind anywhere, was placed in public service on December 7, 1936, in the town of Bruges, Belgium.⁶² This event marked a distinct advance in the evolution of communication systems.

Automatic Toll Ticketing demonstrated the possibility of offering to a telephone subscriber the advantages of full automatic dial service, toll as well as local, previously fully satisfactory only on local service. It makes available an in-

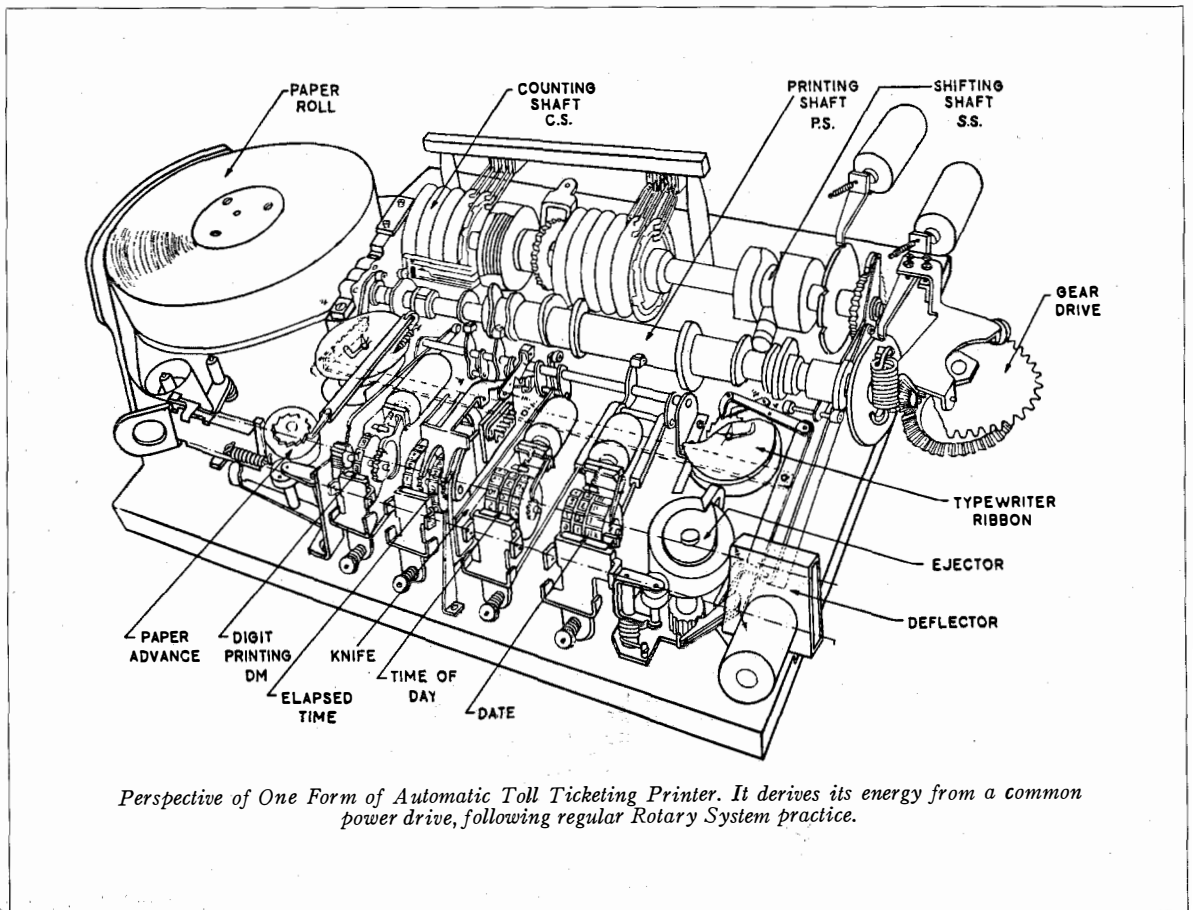

Perspective of One Form of Automatic Toll Ticketing Printer. It derives its energy from a common power drive, following regular Rotary System practice.

dividual and complete printed record of every toll call without participation by any human agency other than the calling and called subscribers.

Without toll ticketing, it is necessary in the case of toll or long distance calls to resort to the preparation of toll tickets by an operator, a cumbersome and time consuming procedure, or the introduction of time and zone metering, furnishing merely an integrated record of unit charges and often involving burdensome equipment alterations. Automatic toll ticketing, on the other hand, can usually be introduced with minimum modification of existing systems.

The automatic printing register itself was described in April, 1937;⁶³ applications of automatic ticketing in step-by-step systems and in long distance telephone connections were described in January, 1939⁶⁴ and January, 1940.⁶⁵

Private Automatic Exchanges

A satisfactory type of PABX for use in sizable establishments must be capable of providing the following facilities: calling in an attendant; call-back; transfer of calls; night, restricted, tie-line, conference, preference calling, code and fire services. Such exchanges may embody provisions for the connection of a thousand or more stations and any required number of trunks to the public exchange.^{98, 99}

An outstanding example of a PABX was that of the great Danish newspaper, Politiken. To provide the reliability and speed necessary in handling last minute news events, a board of the Standard Electric 7D type with its simple and robust apparatus, as well as its high speed 100-point selector, was chosen.¹⁰⁰

An unusual installation¹⁰¹ was that of the Belgian Administration for Civil Air Transport, operating four airports located at Brussels, Antwerp, Ostend and Zoute. Regular national services, both freight and passenger, in addition to considerable international traffic, were handled through them.

Private exchanges interworking amongst the four airports involved special problems, due partly to their wide separation and to the necessity of equipping the loaded cable pairs with voice frequency repeaters. Inasmuch as ordinary d-c dialing could not be used, it was found necessary to resort to 50 cycle signaling, the

principles used in automatic long distance dialing being applied.

Transmission

The facility and speed with which communications can be obtained over local, continental and intercontinental networks bear proof of the outstanding achievements made possible through organized research and development in the art of speech and signal transmissions. Progressing from open wire systems to cable for local tele-

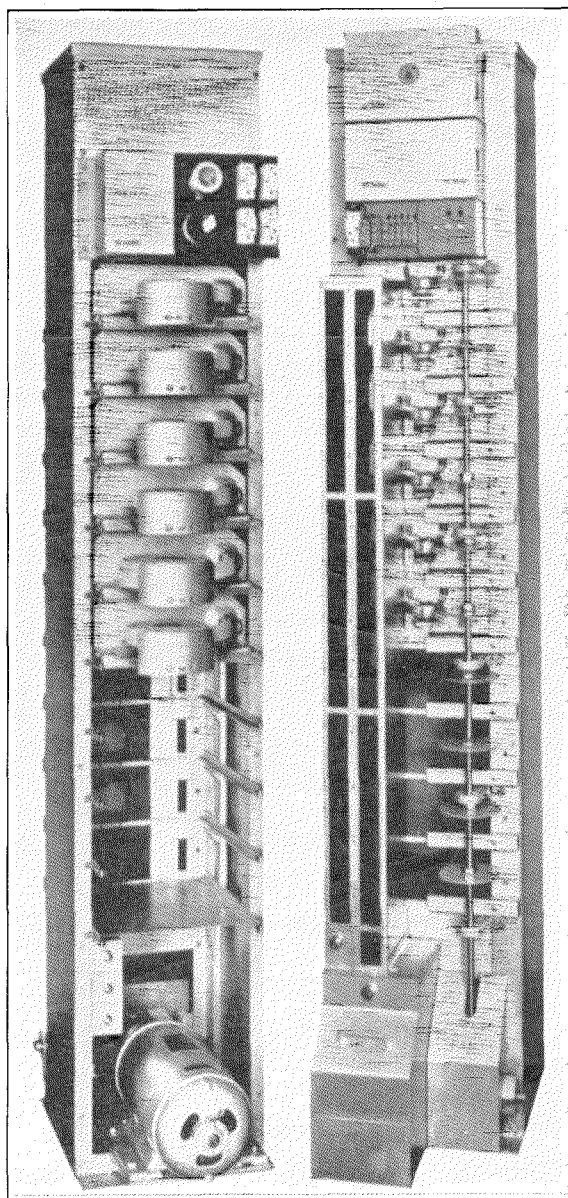

Automatic Toll Ticket Printer Bay, Front and Rear Views.

phone networks, loaded cables, phantomed circuits, vacuum tube repeaters, 2- and 4-wire systems, 1- and 3-channel carrier systems, today broad band carrier systems play a predominating role. Prominent in the development of the broad band systems were improved molybdenum-permalloy dust coils, crystal filters, feedback amplifiers and dry metallic modulators. These developments will be considered in an article on transmission which is scheduled for early publication in *Electrical Communication*.

Many articles in this journal have been devoted to substantial additions to the world's telephone wire and cable network. Their importance will be appreciated when it is considered that wire and cable networks, in addition to their fundamental value in the communication services, are indispensable to international connections on a subscriber-to-subscriber basis inasmuch as radio links, despite their essential nature, must in general be considered solely as adjuncts to local, national and international wire networks.

LOADED AND REPEATERED CABLE

It is interesting to note that the first toll cable installation described in *Electrical Communication* (1923)¹⁰² was that of the first telephone toll cables installed in Japan. They were the Osaka-Kobe and Tokyo-Yokohama cables (each approximately 22 miles in length), and consisted of 52 quads, loaded throughout with medium heavy loading for side and phantom circuits.

Important in connection with future international telephony was the new Simplon tunnel cable, connecting Switzerland and Italy, which was completed in 1922.¹⁰³ Great care was required in its design to avoid interference from power circuits in the tunnel and also to ensure a standard of performance satisfying not only immediate requirements but, in addition, future requirements, such as would be imposed by the introduction of telephone repeaters.

The Milan-Turin-Genoa underground cable installation was begun in December, 1922. It provided 2- and 4-wire physical and phantom circuits, and was a loaded and repeatered cable.¹⁰⁴ Plans provided for connection at Casteggio of future projected cables.

The success of the Milan-Turin-Genoa underground cable installation was demonstrated by

a great increase in traffic. After the completion of the contract, a study was made of a main cable system extending through the whole country and also connecting the rest of Europe via Switzerland and Austria. Subsequently, an order was placed for a complete system of loaded and

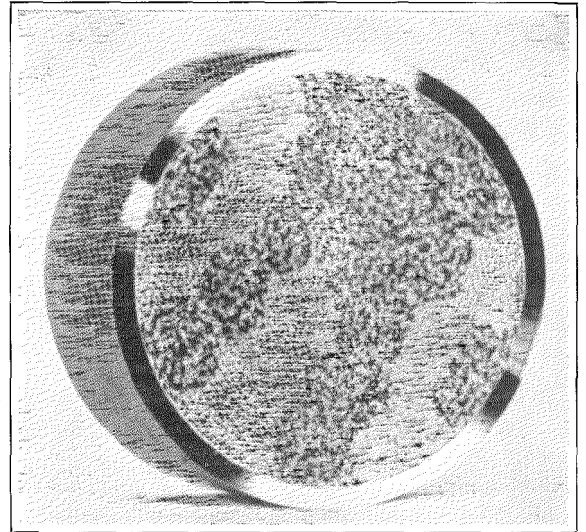

2,400 Pair "Loop" Telephone Cable (4,848 Conductors in a Single Sheath). It has the largest number of pairs ever manufactured commercially.

repeatered cables from Chiasso and Tarvisio on the Swiss and Austrian borders of Italy, to Naples, via Bologna, Florence and Rome.¹⁰⁵

Sweden was the first country in Europe to obtain a completely up-to-date cable of the magnitude provided by the telephone cable between Stockholm and Gothenburg¹⁰⁶ (1923), a distance of 458 km. It was a lead covered but unarmored quaded cable loaded for side and phantom circuits and provided with repeaters.

Factors accelerating expansion of the Swedish cable systems included railway electrification and consequent interference with open wire telephone circuits, rapid growth of telephone traffic and economic considerations. In the Stockholm-Norrköping¹⁰⁷ telephone cable system, projected to form part of the Stockholm-Malmö cable, a later system of loading and also, for a certain type of circuit, the four wire transmission system was adopted. Medium-medium loading was used on the Stockholm-Gothenburg cable; on the Stockholm-Norrköping cable, medium-heavy and extra light loading were chosen, thus obtaining an increase of the cut-off frequency. When the

cable route was comparatively near to the railway line, the cables were armored with two layers of iron bands.

The Stockholm-Malmö system included circuits of the following types:

- 4-wire circuits with extra light loading for long international lines;
- 4-wire circuits with medium-heavy loading for other international and long inland lines;
- 2-wire circuits with medium-heavy loading for the remaining lines.

The Stockholm-Gothenburg¹⁰⁸ and the Stockholm-Malmö¹⁰⁹ railway cables, totaling 458 and 936.3 km in length, respectively paralleled the rail routes, and provided the latest technique then developed. Their design involved special problems of induced voltages and interference with speech currents.

In an article on the London-Glasgow trunk telephone cable¹¹⁰ the London-Derby No. 2 cable, which represented the most modern practice in telephone cable manufacture and installation, and the repeater stations between London and Glasgow, were described. This cable was of particular interest because of the density of traffic handled and the segregation of the 4-wire circuits in the Up and Down groups, while the 2-wire circuits formed the center of the cable. Incidentally, the London-Fenny-Stratford section paralleled the old London-Birmingham loaded cable; its completion by a predecessor organization of Standard Telephones and Cables, Ltd., was cited in 1915 as marking the first stage in the realization of the scheme for connecting London and Liverpool by means of an underground telephone cable.¹¹¹

An outstanding event from the viewpoint of European international long distance telephony

was the completion in September, 1926, of the Paris-Strasbourg Cable,⁶⁸ 494 km in length. It traverses several important industrial areas, such as Champagne, Lorraine and Alsace: the first famous for its wines, the second for its heavy industries and the last for its agricultural products. In addition to providing communication between Paris and these areas, international telephone traffic was dealt with by connections from Paris to England and Belgium; northern and central Germany, via Nancy and Strasbourg; and Switzerland and Italy through Selestat.

On the main route between Paris and Strasbourg, two sizes of cables, both with telephone and telegraph quads were employed. Telegraph quads were in the center of the cable and screened from the telephone quads by means of a layer of aluminum tape. From Paris to Selestat (450 km) the cable consisted of:

66 quads of 0.9 mm conductors	}	for telephone
16 quads of 1.3 mm conductors		working
12 quads of 1.3 mm conductors		—for telegraph working
and, from Selestat to Strasbourg, (44 km) of:		
42 quads of 0.9 mm conductors	}	for telephone
22 quads of 1.3 mm conductors		working
7 quads of 1.3 mm conductors		—for telegraph working.

The principal items of repeater equipment at each of the seven repeater stations are listed in the table below.

Other interesting toll cable systems described in this journal were those of the Danish Telegraph Administration's network,¹¹² all the later cables including specially screened, light-loaded circuits for the Broadcasting Administration;

	4-Wire Repeaters		2-Wire Repeaters		Voice Frequency Ringers		4-Wire Terminating Sets	
	Initial	Ultimate	Initial	Ultimate	Initial	Ultimate	Initial	Ultimate
Paris	75	84	94	140	69	103
Viels-Maisons	31	79	36	51
Chalons	75	84	5	7
Stainville	31	79	36	51	3	3
Nancy	75	89	1	7	22	24	8	8
St. Die	30	63	37	46	4	9	4	20
Strasbourg	26	26	5	5	31	32	25	26
Totals	343	504	115	160	156	212	109	160

and the Hong Kong-Canton toll cable,¹¹³ part of which comprised a submarine section across Hong Kong Harbor from Hong Kong to Kowloon, which was protected by brass tape and heavy steel armor, manufactured in one length of 2,200 yards and balanced in the factory of Standard Telephones and Cables, Ltd., London.

The Czechoslovakian Administration realized early that a really efficient long distance telephone service between chief centers would aid materially in the development of the Republic. Plans for a modern toll cable network provided for national as well as international service.¹¹⁴ As an example of international cooperation and coordination, it may be stated that the orders for repeater equipment and loading coils were placed on Standard Electric Doms A Spolecnost, Prague; the repeater equipment was manufactured by the Bell Telephone Company, Antwerp; the loading coils were produced by Standard Telephones and Cables, Ltd., London, The Bell Telephone Manufacturing Company, Antwerp, and Le Matériel Téléphonique, Paris, all associated companies of the International Telephone and Telegraph Corporation. The cable was of "Standard" type with the exception of sections crossing the Austrian and German frontiers, and was manufactured and installed under advice of the International Standard Electric Corporation.

VOICE FREQUENCY TELEGRAPH SYSTEMS

In the April, 1925, issue of *Electrical Communication* a voice frequency telegraph system was described;¹¹⁵ it gave good service for a number of years, but improvements in the communication art and in apparatus design and equipment practice offered opportunities of developing a more effective system¹¹⁶ intended primarily to provide up to eighteen 2-way telegraph channels on a 4-wire cable circuit. At the time the description was published (1932), two systems of this type, comprising 12 channels, were already in operation on 4-wire circuits in Great Britain and France. The system is applicable to various types of circuits, the most usual being the 4-wire loaded and repeatered cable circuit. When operated over a 2-wire circuit, the number of channels obtainable is reduced by half since in this case different frequencies are used for transmission in the two directions.

1- AND 3-CHANNEL CARRIER SYSTEMS

The first carrier systems outside of the U. S. A. were installed in Brazil (1924) and Australia (1925).⁶⁶ Australia was the first to use the C-2-F Carrier System to provide long haul single channel carrier systems for connecting Melbourne with important farming centers in Victoria and South Australia.⁶⁷ This marked a further step towards the Telephone Administration's goal of providing a highly efficient nation-wide telephone service. That this task represented a considerable undertaking will be appreciated when it is considered that Australia is 25 times as great in area as England and its population is less than that of London.

"If you speak from New York to Brisbane, from Oslo to Madrid, from Bucharest to Buenos Aires, or from London to Angora, some part of the circuit will be a 'Standard' carrier channel." As early as 1932, the International Standard Electric Corporation or its Licensee Companies had furnished carrier equipments as follows:⁶⁶

Country	Number	Country	Number
Argentina.....	44	Italy.....	14
Australia.....	165	Japan.....	41
Austria.....	2	Lithuania.....	2
Brazil.....	5	Malaya.....	17
Bulgaria.....	6	Mexico.....	4
Canada.....	55	Morocco.....	6
Ceylon.....	2	New Zealand.....	53
China.....	12	Norway.....	9
Cuba.....	8	Rhodesia.....	4
Czechoslovakia.....	7	Rumania.....	50
Finland.....	22	Russia.....	5
France.....	109	South Africa.....	23
Great Britain.....	30	Spain.....	74
Hungary.....	10	Sweden.....	94
Iceland.....	2	Turkey.....	3
India.....	10	Yugoslavia.....	6
Irish Free State.....	1		
			895

The latest data would be interesting but, because of disturbed world conditions, are not available.

The longest 3-channel system over open-wire lines ever undertaken was recorded by Standard Telephones and Cables, Ltd., London, in 1938 as in process of construction: the Russian system for the Moscow-Khabarovsk route—8,620 km in length. It included a broadcast program channel.¹¹⁷

BROAD BAND SYSTEMS

The British General Post Office for about the past five years has planned the extension of its network largely on the basis of modern multi-

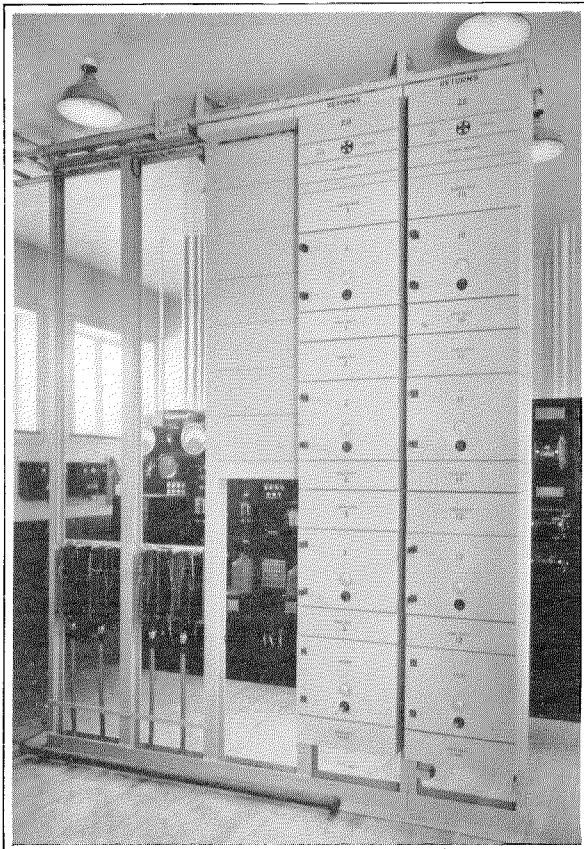

Amplifier Equipment for Unattended Repeater Stations—Bristol-Plymouth 12-Channel Carrier System Type. Power supply equipment is in background; batteries are in separate room. Equipment shown provides for 6 twelve channel systems (both directions).

channel carrier technique. An outstanding example is the Bristol-Plymouth 12-channel carrier system,⁶⁹ providing 12 channels per pair in the 12 to 60 kc range with separate cables for the two transmission directions. The system was designed, when fully equipped, to provide 228 circuits.

At the end of the year 1938, incidentally, over 3,760 km of 12-channel cable were completed or under construction in Great Britain, representing a route length of 1,880 km.¹¹⁸ During 1939 (the latest figures available) 900 km of 12-channel cable were installed; 1,100 km were under construction or on order.¹¹⁹

Taking future television development into account, the G.P.O. pioneered in the installation of coaxial cables. Additions to the telephone network in Great Britain during 1937 included an extension of the London-Birmingham coaxial

cable, i.e., the Birmingham-Manchester-Leeds-Newcastle coaxial systems for telephony and television. At the end of 1937, 350 km route length of such cable was under construction (containing four coaxial cores).⁷⁰ It is interesting to note that the London-Birmingham coaxial cable employed Cotopa as an insulating material in order to achieve low high frequency loss and phase angle, etc.¹⁴⁰

Australia installed the first open wire type J Carrier Telephone System outside of the U. S. A. on the Sydney-Melbourne route. It provides 12 channels on a single pair in addition to 3 channels already derived from a type C system and the normal voice frequency circuit, yielding a total capacity of a pair thus equipped of 16 circuits.¹²¹ A second similar system on this route is planned for installation late in 1942.

In 1940, the latest link in the Swedish toll cable system was completed by joining the two cities of Göteborg and Malmö, a distance of 277 km, by a 12-channel carrier cable system.¹²² In Finland, a similar installation recently was completed.

FUNDAMENTAL TRANSMISSION PLANNING OF TELEPHONE NETWORKS

Following a series of C.C.I.F. recommendations entitled, "Guiding Principles for the General European Switching Plan," a series of two articles considered local and toll area planning to meet the C.C.I.F. recommendations.¹²³ Part I dealt with the general transmission problem imposed by these recommendations, consideration being given to maximum permissible transmitting and receiving losses in the national systems if the agreed overall limits for an international connection were to be met. Part II discussed some of the practical steps necessary in coordinating national design so as to meet the international limits.

On occasions too great to enumerate, this journal has published articles relating to the development and coordination of European national and international networks, commencing with Sir Frank Gill's above cited suggestions which led to the formation of the C.C.I. Members of the I. T. & T. and associate companies frequently have been in a position to make constructive suggestions to the C.C.I. (the C.C.I.F., C.C.I.T. and C.C.I.R.) as a result of broad ex-

perience: through research, development and manufacture in different countries; the supply of communication equipment throughout the world; development and operation of telephone properties on four continents; operation of radio and land line systems linking four continents telephonically; and operation of telegraphic radio links and submarine cable systems on a world-wide basis.

SUBMARINE CABLE SYSTEMS

Along with the provision in 1929 of the above-mentioned Spanish-South American radiotelephone link, a radio link between Spain and the Canary Islands was established with a submarine cable interconnecting the islands of Tenerife and Gran Canaria. In addition, a submarine cable was laid between Algeciras, Spain, and Ceuta, Spanish Morocco. These multi-channel carrier telephone cables were of a special type, the core of which was insulated with gutta percha surrounded with copper wires serving as a sea-return conductor. In addition to the special type of

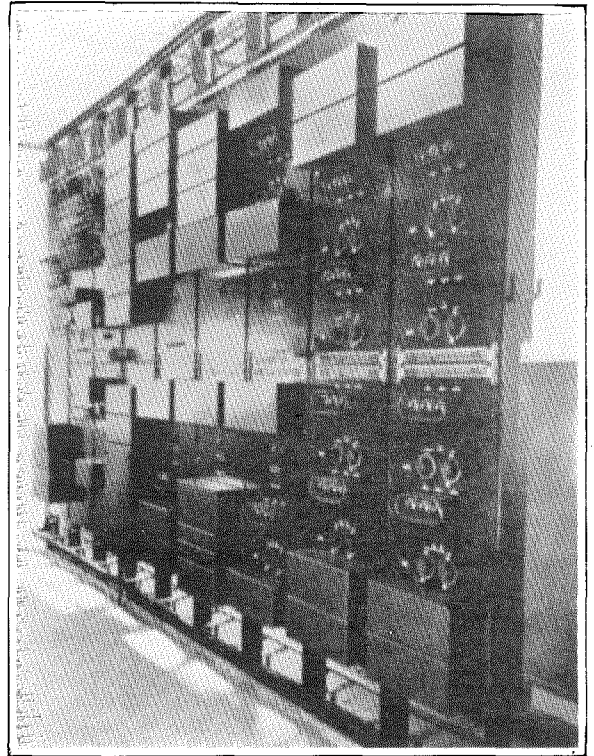

Cable Equipment, Stanley-New Bass Strait Submarine Cable System.

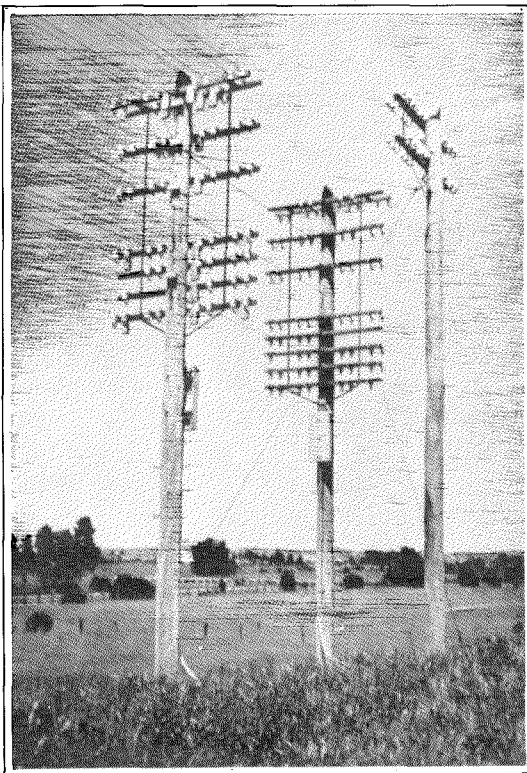

Sydney-Melbourne 12-Channel Carrier Telephone System. Typical Y-Pole Arrangement.

core, an important factor was the improvement in the method adopted for the allocation of the core lengths to obtain smooth impedance distribution, whereby a singing point of 50 db was attained up to a 30 kc frequency. Further, the scheme of measuring attenuation was such that tests were conducted up to 50 db by the "open and short" method.¹²⁴

The world's two longest submarine telephone cables were described in this journal: (a) the Italy-Sardinia Cable¹²⁵ (146 nautical miles); and (b) the cable system between the Australian mainland and the island State of Tasmania¹²⁶ (160.97 nautical miles) consisting of two sections with a repeater station at King Island.

The latter project (known as the Bass Strait Submarine Cable System) employs a single non-loaded central conductor with coaxial return. The system represented the first case in which reversed feedback amplifiers were used in a submarine cable. In addition to being longer, the cable system is operated with frequencies higher than any other submarine cable telephone system. The following table shows the terminating

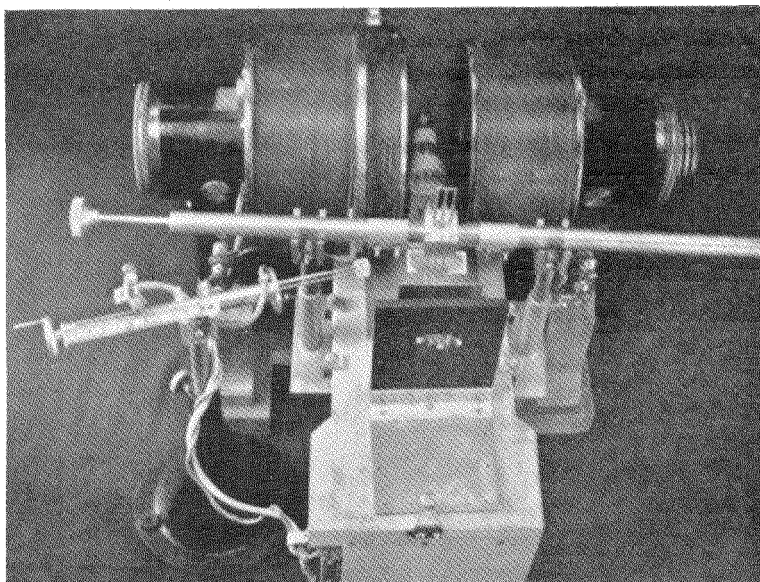

Magnetron. Showing the Generator of Oscillation at a Wavelength of 2.5 cm (In Air) and Its Associated Wave Meter; Also, the Method of Coupling to a Dielectric Guide 1.6 cm Internal Diameter.

points for the various circuits required initially and also for those to be provided subsequently:

	Type of Com. Channel	Melbourne-Launceston	Melbourne-Hobart	Total
Initial Installation	Duplex Teleph.	3	—	3
	Duplex Teleg. Broadcast Program (reversible channel)	3	2	5
Later Additional Installation	Duplex Teleph.	—	1	1
	Duplex Teleg.	—	2	2
	Duplex Teleg.	1	1	2

The system was designed and the equipment manufactured by Standard Telephones and Cables, Ltd., London. The cable was manufactured and laid by Siemen Bros. & Co., Ltd.

DIELECTRIC (CYLINDRICAL) GUIDES

International Telephone Laboratories for over ten years have concentrated attention on ultra-high frequency technique, not only in the radio field, such as micro-ray transmission systems with concentrated beams working on 1600 mc, but also in connection with dielectric (cylindrical)

guides, coaxial cables, etc. Theoretical relationships, transmission irregularities of various types of waves and their effect on communications and television, as well as ultra-high frequency wave characteristics, have been studied.^{26 to 35 incl.}

Printing Telegraphy

To meet the requirements of telegraph exchange service, Creed & Co., Ltd., London, designed a modified teleprinter arranged on a unit basis so that, in the event of trouble, any unit of the machine could readily be replaced in the field. In general, the principle of operation of earlier type machines was retained, but in the machine developed for teleprinter exchange service a special device was incorporated for transmitting back to the calling subscriber the exchange and number of the called subscriber, thus verifying the correctness of the connection.¹²⁷

The introduction of Teleprinter Systems accelerated service, reduced costs and influenced telegraph practice markedly. On the other hand, experience in the field focused attention on the desirability of providing teleprinters with a keyboard conforming strictly to that of the com-

mercial typewriters. This at one time was considered impracticable as it appeared to necessitate the introduction of a six unit code, thus precluding intercommunication with existing systems.

Creed & Co. solved this problem by retaining the established five unit code but arranging for the automatic insertion of a shift signal whenever the sending of a figure or punctuation mark was required. To transmit this additional signal without slowing down operation, a storage device was provided, holding the permutations corresponding to the key last depressed until the appropriate shift signal had been transmitted automatically. This cleared the way for a keyboard conforming strictly to the commercial typewriter layout.¹²⁸

Progress initiated by the introduction of Teleprinter Systems requiring no telegraphic skill on the part of operators altered the whole outlook of telegraphy and stimulated development in all its branches. "All the older types of machines are rapidly being superseded by Teleprinters (1938); and even hand Morse working—the backbone of telegraphy for more than a century—has now been abandoned by the British Telegraph service, the bulk of the traffic being handled by Creed Teleprinters." With parallel developments in other countries, a "New Telegraphy" was evolved. To meet modern requirements, the Creed No. 10 Tape Teleprinter was introduced.

The No. 10 Teleprinter¹²⁹ is radically different in design from other Creed Teleprinter Systems and incorporates mechanisms entirely new in the printing telegraph art. It employs the principle

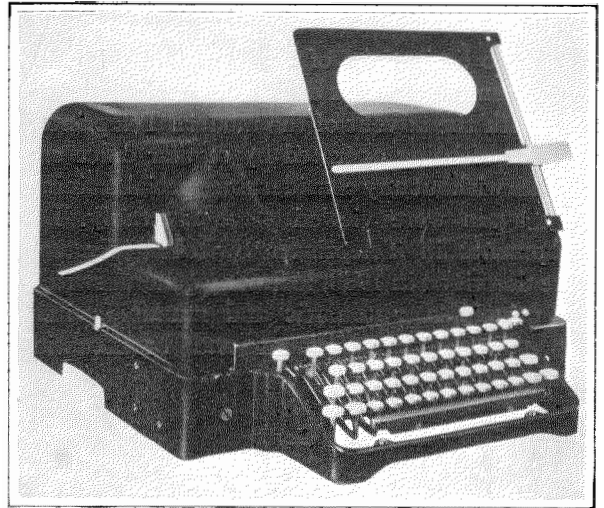

Combined Sending and Receiving Creed 10-B Teleprinter.

of aggregate motion, the difficulties encountered by earlier telegraph inventors in engineering this simple and positive method of controlling a type-wheel being overcome by evolving a novel patented system of epicyclic gearwheels operated by means of ratchet clutches so as to impart harmonic motion to the individual gear wheels and the typewheel. Hence, comparatively noiseless operation is achieved. Further, this Teleprinter is capable of operating at higher speeds than existing types and provides more economical maintenance.

In 1932, an ingenious method was described for the electrical conversion of the non-uniform length combinations of the cable (Morse) Code into a modified five unit code.¹³⁰ This method solved the problem of direct printing over long non-loaded submarine telegraph cables and has been applied successfully in the Commercial Cable and All America cable systems.

The Commercial Cable and All America cable systems generally employ an automatic printer operated directly from 3-element cable code signals. By means of specially devised translators the 3-element signals may be translated into 2-element signals for transmission over ordinary landline telegraph plant; conversely, the 2-element signals may be restored to their 3-element form and, also, they may be monitored without retranslation. Synchronism between translators and retranslators is not required.¹³¹



Creed Teleprinter with Keyboard Conforming Strictly to the Commercial Typewriter Layout.

TELEPRINTER SWITCHING SYSTEMS

Due to limitations of now obsolete telegraph instruments, telegraph exchanges fell into disuse, but, with the advent of the modern Teleprinter, capable of being operated by regular office employees without any considerable special training, they again were viewed more favorably. Developments in Teleprinter Switching Systems were described in 1938, including general switching principles, automatic and manual switching, substation equipment and broadcasting arrangements.¹³²

Supervisory Remote Control

In recent years supervisory control equipment has found increasing application, such as in railway and traction systems, involving the remote control of substations through which the high tension supply is ultimately fed to the track or trolley wire systems. Plans for development of railway electrification schemes in England and, more particularly in the environs of London, lent special interest to two such installations on suburban railway systems for the supervisory control of unattended substations, i.e., those of the London, Midland and Scottish Railway Company and the London Underground Railways.

The operating fundamentals and range of facilities generally are similar in both installations, which embody the principles of the Constant Total Code System.^{133, 134} Facilities provided by the L.M.S. Railway installation include:

- (a) Control and indication of:
 - (1) 13 Rotary Converters
 - (2) 5 Mercury Arc Rectifiers
 - (3) 17 E.H.T. Feeder Breakers
 - (4) 25 Track Feeder Breakers
 - (5) 2 Protection Circuits.
- (b) Control of Mass Firing of 12 Track Feeder Breakers in pairs at adjacent sub-stations.
- (c) Indication of:
 - (1) 13 E.H.T. Breakers
 - (2) 2 Rotary Converters
 - (3) 4 Track Feeder Breakers
 - (4) 2 Tunnel Trip Circuits.
- (d) Selection of any of 19 readings of d-c volts and amperes.
- (e) Constant proving of line continuity.
- (f) Means for switching control and substation equipment to or from spare line.

- (g) Indication of remote and local fuse alarms.
- (h) Routine testing access equipment with portable test sets.

Standard Telephones and Cables, Ltd., London, in the early nineteen-thirties gave attention

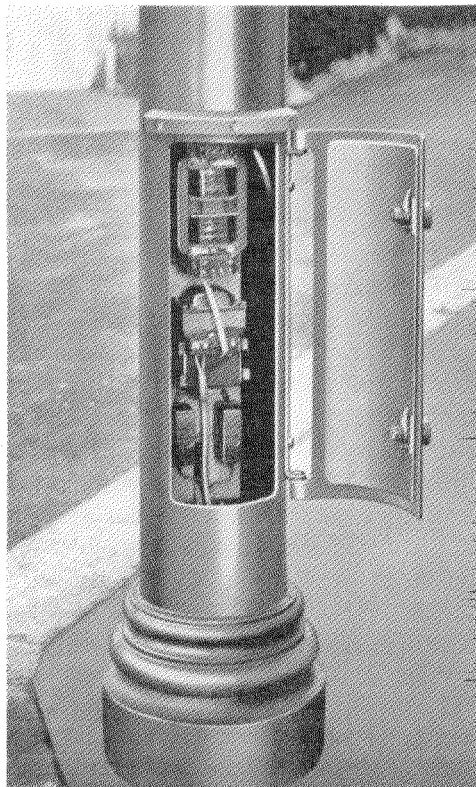

Remote Control over Power Mains of Street Lighting, Water Heating and Other Services. Lighting unit mounted in base of street post.

to the problem of remote control of street lighting; and, after considering expensive schemes depending on the utilization of high frequency alternating current, concluded that a considerably cheaper method might be adopted, involving the application of a d-c bias to the network. With the development of a ready means of separating the a-c from the d-c at the receiving lamp post, the S.T.C. Direct Current Bias System was evolved.¹³⁵ The system has the very great advantage that it can be applied in the first instance locally to particular districts of a network and, as other methods or equipment in use elsewhere become due for replacement, it can be extended until the whole of the street lighting of a town is controlled from one point. The system

is low in initial cost, thoroughly reliable, and simple and robust in design.

The City of Lichfield (England) was one of the first to adopt this d-c bias system for the control of street lighting and other services. On the night of March 8, 1938, the City Engineer, with the cooperation of the authorities gave a demonstration of the use of the system for the control of street lighting, the operation of air raid alarms, and the calling out of volunteer firemen and air raid wardens to some two hundred engineers from all parts of Great Britain.

The application of telephone technique and telephone type apparatus has been greatly extended in the control circuits of heavy electrical equipment. An example is an order received by S.T.C. for the supply of remote control, indication and telemetering equipment for ten substations on the new extension of the London Passenger Transport Board's underground railway from Highgate over the London & North Eastern Railway Company's lines to High Barnet and Edgware.¹³⁶

Esterified Fibrous Insulating Materials

In January, 1935, the first of a series of articles on the above subject was published in this journal; it cited a new material, Cotopa, as an example of fibrous materials especially produced for electrical engineering purposes by modifying their chemical structure. Its outstanding value was shown to be its high insulation resistance—superior to cellulose acetate silk, the best textile insulator previously known. It is comparable with cotton in mechanical strength and running properties in machines. In these characteristics and in its higher decomposition temperature, Cotopa is much superior to acetate silk, and is immune from attacks by fungi or mildew.¹³⁷

Following the general survey of the application of fibrous materials to electrical insulation and of the improvement from an electrical viewpoint produced in cellulosic materials by acetylation (Part I), the practical details of manufacture, application and testing of these acetylated cellulosic fibrous materials was treated more fully. A short dissertation of modern ideas on the structure of cellulosic materials was added (Part II).¹³⁸

Previous indication that a new technique of insulating materials was appearing on the horizon

and that the insulation of the future will be prepared synthetically or will be chemically processed to eliminate inherent natural defects was illustrated in Part III:¹³⁹ (1) improvement of processing of acetylated cotton to a stage providing insulation ten to twenty times superior to any insulation previously known; (2) development of processes for the analogous treatment of natural silk and wool to meet the demand for high grade insulation with fireproof characteristics superior to those obtainable from cellulosic materials.

Recent developments in and the properties of various fibrous insulants including acetylated paper were discussed in 1940.¹⁴⁰

High Tension Developments

Standard Telephones and Cables, Ltd., London, for the past 15 years has been active in the power field, both in its development and manufacturing aspects. In order to insure the production of high quality power cables, the problem of adequate testing has been continuously studied.¹⁴¹ Notable developments are the Condenser Cone and Styrene.

In the high power cable field, terminations and joints are of prime importance. For these applications, the Condenser Cone¹⁴² effected a startling improvement in the ability of cable ends to withstand high voltages. It is cheap to construct, easy to install, and its range of application is wide.

In 1937, 1938 and 1940 a notable series of articles was published on the utilization of styrene in high tension cable systems.¹⁴³ Since 1938 much research has been undertaken to extend styrenation technique in the light of experience gained under service conditions, and new methods of making styrene joints, plugs and terminations have been evolved. Simplification and cost reduction have been carried to the stage where general use can be made of barrier action in cables. Bonded styrenated paper also has been introduced as a product likely to have widespread commercial application.

The International Telephone & Radio Manufacturing Corporation, as a result of development progress in the power cable field in connection with joints and terminations, is preparing for the manufacture of styrenated papers, styrene rubber, etc. It is felt that in the near future styrene, not only in the H.T. insulation field, but also in



Symbol of Neighborliness in South America. At the feet of Christ of the Andes, I. T. & T. engineers and installers burying the transcontinental cable interconnecting Argentina and Chile.

the high frequency insulation field, is likely to become more universal.¹⁴⁵

Conclusion

In concluding this survey of the past twenty years, it is fitting to give grateful recognition to Pioneers of Electrical Communication who laid the foundation for the astounding achievements of our age in electrical communications. A series of biographical articles, embodying considerable original material, was published in *Electrical Communication* in the years 1926–1929. The pioneers included were: James Clerk Maxwell, André Marie Ampère, Alessandro Volta, Charles Wheatstone, Heinrich Rudolph Hertz, Hans Christian Oersted, Georg Simon Ohm, Oliver Heaviside, and Claude Chappe. Recently an article on Peder Oluf Pedersen appeared.^{146 to 155 incl.}

Because of the size of this review, much material has been omitted or mentioned only incidentally. The Selenium Rectifier, on which articles have recently been included in this jour-

nal,^{157, 158} and numerous descriptions of activities of I.T. & T. Associate operating telephone, telegraph and radio companies are cases in point. One article—too lengthy for summarization—is deserving of special emphasis: “Operations of the International Telephone and Telegraph Group of Companies in the Americas.”⁷² It shows quite clearly the contributions which the I.T. & T. Corporation and its Associate Companies have made to Western Hemisphere communications, particularly in South America.

An exemplification of these contributions is afforded by the following quotation from *Electrical Communication* referring to Western Hemisphere Broadcast Networks, President Roosevelt’s Fireside Chat of May 27, 1941:¹⁵⁶

“Wide dissemination of programs of this character thus can be effected only through local medium wave broadcast stations to which every radio set owner is a potential listener. For adequate national or international hookups, furthermore, local stations must be served by high

quality wire networks or radiotelephone circuits (inter-linked radio stations). It is, accordingly, a happy circumstance that the International Telephone and Telegraph Corporation, primarily due to its activities in developing local, national and international communications in the Southern continent, has at its disposal both wire networks and national and international radiotelephone stations for providing program transmission service to the broadcast stations in many of the important countries in the Western Hemisphere."

* * *

"Reports confirmed the excellent transmission quality and the interest evoked by the address. The South American network, giving coverage to an estimated ten million listeners, was the most comprehensive ever established on that continent for a single program originating in the U. S. A."

An indication of the world-wide scope of the contributions recorded in *Electrical Communication* may, perhaps, best be gleaned by recalling The Coronation of Their Majesties King George VI and Queen Elizabeth in London on May 12, 1937. In broadcasting the Coronation Ceremony from Westminster Abbey, Standard Electric types of equipment included:⁸³

"The microphones used for picking up the Abbey service and the cheers of the vast crowds; four of the B.B.C. Empire broadcast transmitters (two of these were the new high power stations, the installation of which was specially expedited for this purpose, and two were older, lower power stations); the international telephone exchange toll test racks through which all the telephone

circuits were set up; the radio transmitters used on several of the radiotelephone circuits; radiotelephone and switching facilities in Argentina, Brazil and other countries; and radiotelephone equipment in hundreds of ships including liners such as the Cunard White Star *Queen Mary* and *Berengaria*. The wire telephone circuits to the 13 European countries included much Standard type apparatus in the form of Cable, Loading Coils, Repeaters, Carrier Equipment, Toll Switchboards, etc. . . . Standard type broadcasters in numerous countries were involved in retransmissions of the programs."

Modern war inevitably imposes requirements that press heavily even on the most comprehensive communication networks. Moreover, demand for the completion of fundamental research and development projects carried out in laboratories of private companies, often with a view to utilization in the longer future, suddenly becomes urgent. At present, this is especially true in the field of ultra-high frequency technique involving television, dielectric guides, sharply concentrated U.H.F. beams, etc. As may be inferred from citations in this report, the International Telephone and Telegraph Corporation and Associate Companies, fortunately, have for a period of over ten years devoted special attention to the ultra-high frequency field.

Communications, not infrequently, have played their part in events that have become historic; at times, in fact, such as in the telegraphic and telephonic interconnection of continents, they have made history. In time to come the communications art seems destined to play an even greater rôle in its service to mankind.

References

1. "The Future of Long Distance Telephony in Europe," by Frank Gill, *El. Com.*, Vol. 1, No. 2, 1922.
2. "European Long Distance Telephony," *El. Com.*, Vol. 2, No. 2, 1923.
3. "European International Telephony," by Frank Gill, *El. Com.*, Vol. 3, No. 1, 1924.
4. "European Telephony as Affected by the International Telephone Committee—C.C.I.," *El. Com.*, Vol. 6, No. 1, 1927.
5. "The Recent Transatlantic Radiotelephone Tests," *El. Com.*, Vol. 1, No. 3, 1923.
6. "Transatlantic Radiotelephone Transmission," by L. Epenschied, C. N. Anderson and A. Bailey, *El. Com.*, Vol. 4, No. 1, 1925.
7. "Transatlantic Radiotelephony—Radio Station of the British Post Office at Rugby," by E. M. Deloraine, *El. Com.*, Vol. 5, No. 1, 1926. See also "The Rugby Radio Station," by E. H. Shaughnessy, *El. Rev.*, April 30, 1926; May 7, 1926.
- 7a. "Transatlantic Telephony Between the Institution of Electrical Engineers, London, and the Institute of Electrical Engineers, New York," *El. Com.*, Vol. 6, No. 4, 1928.

8. "Madrid—Buenos Aires Radio Link and Its Wire Connections," by G. H. Gray and N. K. Fairbank, *El. Com.*, Vol. 8, No. 4, 1930.
9. "The Use of Short Waves in Radio Communication," by E. M. Deloraine, *El. Com.*, Vol. 8, No. 4, 1930.
10. "The 'Standard' Short Wave Radio Transmitters," by C. E. Strong, *El. Com.*, Vol. 8, No. 4, 1930.
11. "Short Wave Radio Telephone and Telegraph Receivers," by E. H. Ullrich and R. E. Gray, *El. Com.*, Vol. 8, No. 4, 1930.
12. "Thermionic Vacuum Tubes for Short Waves," by W. T. Gibson, *El. Com.*, Vol. 8, No. 4, 1930.
13. "Short Wave Directive Transmitting and Receiving Antennas," by E. H. Ullrich and N. K. Fairbank, *El. Com.*, Vol. 8, No. 4, 1930.
14. "Terminal Equipments for Short Wave Point-to-Point Radio Links," by F. de Fremery and P. R. Thomas, *El. Com.*, Vol. 8, No. 4, 1930.
15. "Inauguration of Madrid-Buenos Aires Radiotelephone Link," by F. T. Caldwell, *El. Com.*, Vol. 8, No. 4, 1930.
16. "The New York—Buenos Aires Radio Circuit," by H. H. Buttner, *El. Com.*, Vol. 8, No. 5, 1930.
- 16a. "The Spread (Displaced) Sideband System on Short Wave Telephone Links," by L. T. Hinton, *El. Com.*, Vol. 10, No. 2, 1931.
17. "The Single Sideband System Applied to Short Wavelengths," by A. H. Reeves, *El. Com.*, Vol. 10, No. 1, 1931.
18. "Micro-Ray Radio," *El. Com.*, Vol. 10, No. 1, 1931.
19. "Production and Utilization of Micro-Rays," by A. G. Clavier, *El. Com.*, Vol. 12, No. 1, 1933.
20. "The Anglo-French Micro-Ray Link Between Lypne and St. Inglevert," by A. G. Clavier and L. C. Gallant, *El. Com.*, Vol. 12, No. 3, 1934.
21. "Micro-Ray Communication," by W. L. McPherson and E. H. Ullrich, *El. Com.*, Vol. 14, No. 4, 1936.
22. "Propagation Tests with Micro-Rays," by A. G. Clavier, *El. Com.*, Vol. 15, No. 3, 1937.
23. "Superheterodyne Reception of Micro-Rays," by A. H. Reeves and E. H. Ullrich, *El. Com.*, Vol. 16, No. 2, 1937.
24. "Ultra-Short Wave Communication," by E. H. Ullrich, *El. Com.*, Vol. 16, No. 1, 1937. See also "Bellfast-Stranraer 9-Circuit Ultra-Short Wave Radiotelephone System—Part II," by D. B. Mirk, *P.O. Elec. Engrs. Jnl.*, pp. 33–40, April, 1938.
25. "The Eiffel Tower Television Transmitter," by S. Mallein and G. Rabuteau, *El. Com.*, Vol. 17, No. 4, 1939.
26. "Some Problems of Hyperfrequency Technique," by A. G. Clavier and E. Rostas, *El. Com.*, Vol. 16, No. 3, 1938.
27. "Theoretical Study of Dielectric Cables," by L. Brillouin, *El. Com.*, Vol. 16, No. 4, 1938.
28. "General Properties of Dielectric Guides," by J. Saphores, *El. Com.*, Vol. 16, No. 4, 1938.
29. "Theoretical Relationships of Dielectric Guides (Cylindrical) and Coaxial Cables," by A. G. Clavier, *El. Com.*, Vol. 17, No. 3, 1939.
30. "Experimental Researches on the Propagation of Electromagnetic Waves in Dielectric (Cylindrical) Guides," by A. G. Clavier and V. Altovskiy, *El. Com.*, Vol. 18, No. 1, 1939.
31. "Hyperfrequency Waves and Their Practical Use," by L. Brillouin, *El. Com.*, Vol. 19, No. 4, 1941.
32. "Electromagnetic Waves in Metal Tubes of Rectangular Cross-Section," by J. Kemp, *El. Com.*, Vol. 20, No. 2, 1941.
33. "Theory of the Magnetron," by L. Brillouin, *El. Com.*, Vol. 20, No. 2, 1941.
34. "Irregularities in Telephone and Television Coaxial Cables," by L. Brillouin, *El. Com.*, Vol. 17, No. 2, 1938.
35. "Notes on the Effects of Irregularities in Coaxial Cables on Television Transmission," by J. Saphores and P. Gloess, *El. Com.*, Vol. 17, No. 2, 1938.
36. "The Prague High Power Broadcasting Equipment," by D. B. Mirk, *El. Com.*, Vol. 10, No. 3, 1932.
37. "'Standard' High Power Broadcasting Transmitters at Budapest and Kalundborg," by C. E. Strong, *El. Com.*, Vol. 12, No. 4, 1934.
38. "The Budapest Anti-Fading Antenna," by F. Holland, C. E. Strong and F. C. McLean, *El. Com.*, Vol. 12, No. 4, 1934.
39. *El. Com.*, Vol. 16, No. 3, p. 189, 1938.
40. "Ship-and-Shore Terminal Equipment," by A. S. Angwin, *El. Com.*, Vol. 9, No. 1, 1930.
41. "Mobile Radiotelephony," by F. G. Loring and H. H. Buttner, *El. Com.*, Vol. 11, No. 2, 1932.
42. "The Automatic Radio Compass and Its Applications to Aerial Navigation," by H. Busignies, *El. Com.*, Vol. 15, No. 2, 1936.
43. "Reduction of Night Error in Radio Direction Finding Equipment for Aerodromes," by H. Busignies, *El. Com.*, Vol. 16, No. 3, 1938; also, "Control of Night Error in Airplane Direction Finding," by H. Busignies. (A paper presented at the I.R.E. Summer Convention, Detroit, June 23, 24 and 25, 1941.)
44. "Mountain Effects and the Use of Radio Compasses and Radio Beacons for Piloting Aircraft," by H. Busignies, *El. Com.*, Vol. 19, No. 3, 1941.
45. "Development of the C.A.A. Instrument Landing System at Indianapolis," by W. E. Jackson, A. Alford, P. F. Byrne, and H. B. Fischer, *El. Com.*, Vol. 18, No. 4, 1940; *El. Com.*, Vol. 19, No. 3, p. 5, 1941.
46. "Airport Communications," by R. H. Riddle, *El. Com.*, Vol. 20, No. 1, 1941.
47. "High Frequency Transmission Line Networks," by Andrew Alford, *El. Com.*, Vol. 17, No. 3, 1939.
48. "Ultra-High Frequency Loop Antennae," by A. Alford and A. G. Kandoian, *El. Com.*, Vol. 18, No. 4, 1940.
49. "The Rotary Automatic Telephone Introduced Into Paris," by G. Deakin, *El. Com.*, Vol. 7, No. 2, 1928.
50. "Trunking Plans of the Paris Network," by S. V. C. Scruby, *El. Com.*, Vol. 13, No. 2, 1934. See also *Annales Des Postes Télégraphes et Téléphones: "Transformation en Automatique de la Région de Paris,"* by André Duprez, June, 1938; "Adaptation du Réseau Téléphonique de Paris à L'Exploitation

- Automatique de la Région de Paris," by André Blanchard, July, 1938.
51. "A Rural Rotary Automatic Telephone System Installed at Herrliberg," by W. Hatton, *El. Com.*, Vol. 8, No. 1, 1929.
 52. "Automatic Telephony in the Zurich Area," by E. Wollner, *El. Com.*, Vol. 8, No. 2, 1929.
 53. "Rotary Automatic in Switzerland," by G. Deakin, *El. Com.*, Vol. 9, No. 3, 1931.
 54. "Automatic Long Distance Switching and National Dialing—Basle, Switzerland," by E. Frey, *El. Com.*, Vol. 12, No. 4, 1934.
 55. "National Dialing in the Netherlands," by J. P. Verlooy and M. Den Hertog, *El. Com.*, Vol. 17, No. 1, 1938.
 56. "A Field Trial of 50 Cycle Signaling on Toll Lines," by W. Hatton, *El. Com.*, Vol. 15, No. 2, 1936.
 57. "Development Aspects of International Voice Frequency Signaling and Dialing Under Consideration by the C.C.I.F.," by E. P. G. Wright, *El. Com.*, Vol. 18, No. 1, 1939.
 58. "7A-2 Rotary Automatic Telephone System—Part I," by L. Schreiber and W. Hatton, *El. Com.*, Vol. 11, No. 4, 1933.
 59. "7A-2 Rotary Automatic Telephone System—Part II," by L. Schreiber and W. Hatton, *El. Com.*, Vol. 12, No. 1, 1933.
 60. "7A-2 Rotary Automatic Telephone System—Part III," by L. Schreiber and W. Hatton, *El. Com.*, Vol. 12, No. 2, 1933.
 61. "7D Rotary Automatic Telephone System," by W. Hatton and J. Kruihof, *El. Com.*, Vol. 13, No. 4, 1935.
 62. "Automatic Ticketing of Telephone Toll Calls," by Leslie B. Haigh, *El. Com.*, Vol. 15, No. 4, 1937.
 63. "Automatic Printing Register for Telephone Call Recording," by L. Devaux, *El. Com.*, Vol. 15, No. 4, 1937.
 64. "The Application of Automatic Ticketing to Step-By-Step Systems," by E. P. G. Wright, *El. Com.*, Vol. 17, No. 3, 1939.
 65. "Automatic Ticketing of Long Distance Telephone Connections," by W. Hatton, *El. Com.*, Vol. 18, No. 3, 1940.
 66. "Carrier Current Systems Form Important Part of World Communication Network," by J. S. Jammer, *El. Com.*, Vol. 11, No. 2, 1932.
 67. "Australia First to Use Type C-2-F Carrier System," by J. S. Jammer, *El. Com.*, Vol. 7, No. 1, 1928.
 68. "Paris-Strasbourg Cable," *El. Com.*, Vol. 6, No. 1, 1927.
 69. "Bristol-Plymouth 12-Channel Carrier System," *El. Com.*, Vol. 16, No. 2, 1937.
 70. *El. Com.*, Vol. 16, No. 3, p. 186, 1938. See also "Modern Systems of Multi-Channel Telephony on Cables," by A. S. Angwin and R. A. Mack, *Jnl. of the I.E.E.*, Nov., 1937.
 71. "Recent Developments in Electrical Communication," by J. L. McQuarrie, *El. Com.*, Vol. 1, No. 1, 1922.
 72. "Operations of the International Telephone and Telegraph Group of Companies in the Americas," by W. F. Repp, *El. Com.*, Vol. 19, No. 3, 1941.
 73. "The Single Sideband System Applied to Short Wave Telephone Links (Summary)," by A. H. Reeves, *El. Com.*, Vol. 12, No. 2, 1933. For complete paper, see *Jnl. of the I.E.E.*, Sept., 1933; also "La Transmission Radiotéléphonique à Ondes Courtes, à Bande Latérale Unique et Autres Systèmes," by E. M. Deloraine, *Bull. de la Soc. Française des Electriciens*, p. 940, Aug., 1932.
 74. "The Birmingham Broadcasting Station," by A. E. Thompson, *El. Com.*, Vol. 2, No. 3, 1924.
 75. "Broadcasting in South Africa," by F. H. Amis, *El. Com.*, Vol. 3, No. 3, 1925.
 76. "Broadcasting in Sweden, Norway and Denmark," by A. Taranger, *El. Com.*, Vol. 7, No. 1, 1928.
 77. "Iceland and Its First Broadcasting Station," by K. H. Thow, *El. Com.*, Vol. 5, No. 4, 1927.
 78. "The New Swiss Broadcasting Station," by F. C. McLean, *El. Com.*, Vol. 11, No. 1, 1932.
 79. "The Swiss Broadcast Network," by A. Muri, *El. Com.*, Vol. 11, No. 1, 1932.
 80. "Extension of Sottens Broadcasting Station to 100 KW," by E. Metzler, C. E. Strong, and F. C. McLean, *El. Com.*, Vol. 15, No. 1, 1936.
 81. "British Empire Broadcasting," by C. M. Benham and P. H. Spagnoletti, *El. Com.*, Vol. 12, No. 4, 1934.
 82. "British Broadcasting Corporation's Start Point Transmitter," *El. Com.*, Vol. 18, No. 1, p. 105, 1939.
 83. "The Coronation," by F. Gill, *El. Com.*, Vol. 16, No. 1, 1937.
 84. "Columbia Broadcasting System's New 50 KW Broadcasting Station WABC," *El. Com.*, Vol. 20, No. 2, p. 140, 1941.
 85. "Final Stage Class "B" Modulation," by C. E. Strong, *El. Com.*, Vol. 16, No. 4, 1938.
 86. "A New 120 KW Vacuum Tube," by W. T. Gibson and G. Rabuteau, *El. Com.*, Vol. 12, No. 2, 1933.
 87. "Hot Cathode Mercury Vapour High Tension Supply Equipment for Broadcasting Stations," by G. Rabuteau, *El. Com.*, Vol. 15, No. 2, 1936.
 88. *El. Com.*, Vol. 17, No. 3, p. 213, 1939.
 89. "The Radio Installation on the Cunard White Star, R.M.S. Queen Mary," by H. Thorpe-Woods, H. H. Buttner, and E. N. Wendell, *El. Com.*, Vol. 15, No. 1, 1936.
 90. "The Cunard White Star R.M.S. 'Queen Mary' Radio Installation," by F. G. Loring, W. L. McPherson, and W. H. McAllister, *El. Com.*, Vol. 15, No. 4, 1937.
 91. "Q. S. T. S. 'Queen Elizabeth'" (Illustration), *El. Com.*, Vol. 17, No. 2, p. 100, 1938.
 92. "A New Marine Radio Unit for Cargo Vessels," by E. J. Girard, *El. Com.*, Vol. 20, No. 2, 1941.
 93. "Illumination of Presidente Rivadavia (Moron) Airport (Province of Buenos Aires)," by P. B. Padilla and E. T. G. Palmer, *El. Com.*, Vol. 19, No. 4, 1941.
 94. "The Public Address System in Liverpool Cathedral," by A. F. Rickard, *El. Com.*, Vol. 5, No. 2, 1926.
 95. "Vast Public Address System at 31st International Eucharistic Congress, Dublin, June, 1932," by W. L. McPherson, *El. Com.*, Vol. 11, No. 4, 1933.

96. "The Public Address System and Corollary Installations for the 32d International Eucharistic Congress," by R. T. Mulleady and W. White; see also "Transmitting The Program of the 32d International Eucharistic Congress," by K. McKim, *El. Com.*, Vol. 14, No. 1, 1935.
97. "Public Address System at the 34th International Eucharistic Congress," Budapest, May 22-29, 1938," by G. A. de Czeglédy, *El. Com.*, Vol. 17, No. 4, 1939.
- 97a. "The 1937 Paris Exhibition," by P. Quéfféléan, *El. Com.*, Vol. 16, No. 2, 1937.
98. "400 Line PABX-7055 Type," by M. A. Biske, *El. Com.*, Vol. 13, No. 3, 1935.
99. "Private Automatic Branch Exchanges," by W. Hutton and R. T. Ringkjøb, *El. Com.*, Vol. 14, No. 3, 1936.
100. "No. 7D Rotary Automatic PBX Installed in the Administration Building of the Danish Newspaper 'Politiken'," by K. A. Haldvig, *El. Com.*, Vol. 16, No. 2, 1937.
101. "Airport PABX Network," by R. T. Ringkjøb, *El. Com.*, Vol. 17, No. 3, 1939.
102. "Installation of the First Telephone Toll Cables in Japan," by R. P. Ashbaugh, *El. Com.*, Vol. 1, No. 3, 1923.
103. "The New Simplon Cable," by R. A. Mack, *El. Com.*, Vol. 1, No. 4, 1923.
104. "The Work of Installation of the Underground Telephone Cable—Milan—Turin—Genoa," by G. Magagnini, *El. Com.*, Vol. 2, No. 3, 1924.
105. "The Italian State Toll Cable System," by G. di Perro, *El. Com.*, Vol. 9, No. 2, 1931.
106. "The Stockholm—Gothenburg Telephone Cable," *El. Com.*, by E. Ekeberg, Vol. 2, No. 4, 1924.
107. "The Stockholm—Norrköping Telephone Cable," by N. Hedén, *El. Com.*, Vol. 5, No. 1, 1926.
108. "Stockholm—Göteborg Railway Cable," by I. Billing, *El. Com.*, Vol. 4, No. 4, 1926.
109. "Stockholm—Malmö Railway Cable," *El. Com.*, Vol. 10, No. 2, 1931.
110. "The London—Glasgow Trunk Telephone Cable and Its Repeater Stations," by A. B. Hart, *El. Com.*, Vol. 5, No. 2, 1926.
111. "London Birmingham Loaded Cable," *P. O. Elec. Engrs. Jnl.*, Vol. 8, p. 206, 1915.
112. "The Danish Telegraph Administration's Toll Cable Network," by N. E. Holmblad, *El. Com.*, Vol. 14, No. 3, 1936.
113. "Hongkong—Canton Toll Telephone Cable," by P. T. Carey and R. E. Burnett, *El. Com.*, Vol. 10, No. 4, 1932.
114. "Czechoslovakian Cable System," by F. J. Stringer, W. F. Marriage and L. E. Pawley, *El. Com.*, Vol. 8, No. 3, 1930.
115. "Voice Frequency Carrier Telegraph System for Cables," by B. P. Hamilton, V. H. Nyquist, M. B. Long and W. A. Phelps, *El. Com.*, Vol. 3, No. 4, 1925.
116. "A New Voice Frequency Telegraph System," by J. A. H. Lloyd, W. N. Roseway, V. J. Terry and A. W. Montgomery, *El. Com.*, Vol. 10, No. 4, 1932.
117. *El. Com.*, Vol. 16, No. 3, p. 188, 1938.
118. *El. Com.*, Vol. 17, No. 3, p. 209, 1939.
119. *El. Com.*, Vol. 18, No. 3, p. 183, 1940.
121. "The Sydney—Melbourne Type J Carrier Telephone System," by J. T. O'Leary, J. B. Scott, and A. M. Thornton, *El. Com.*, Vol. 19, No. 1, 1940.
122. "12-Channel Carrier Equipment in the Göteborg—Malmö Cable," by S. R. Nordström, *El. Com.*, Vol. 20, No. 2, 1941.
123. "Fundamental Transmission Planning of Telephone Networks," by B. H. McCurdy, *El. Com.*, Part I: Vol. 18, No. 1, 1939; Part II: Vol. 19, No. 1, 1940.
124. "Tenerife—Gran Canaria and Algeciras—Ceuta Submarine Cables," by K. E. Latimer and J. R. Vezey, *El. Com.*, Vol. 9, No. 4, 1931.
125. "The New Italy—Sardinia Telephone Circuit," by A. G. Pession, *El. Com.*, Vol. 12, No. 2, 1933.
126. "The Carrier Telephone and Telegraph Equipment of the New Bass Strait Submarine Cable System," by F. Ralph and R. L. Hughes, *El. Com.*, Vol. 15, No. 4, 1937.
127. "Developments in Start-Stop Telegraphy—The New Creed Printer," *El. Com.*, Vol. 10, No. 2, 1931.
128. "Improved Teleprinter Keyboard Technique," by F. R. Thomas, *El. Com.*, Vol. 13, No. 1, 1934.
129. "The Creed No. 10 Tape Teleprinter," by A. E. Thompson, *El. Com.*, Vol. 16, No. 4, 1938.
130. "Direct Printing Over Long Non-Loaded Submarine Telegraph Cables," by M. H. Woodward and A. F. Connery, *El. Com.*, Vol. 10, No. 4, 1932.
131. "A Cable Code Translator System," by A. F. Connery, *El. Com.*, Vol. 14, No. 3, 1936.
132. "Some Recent Developments in Teleprinter Switching Systems," by P. F. Clemens, *El. Com.*, Vol. 16, No. 3, 1938.
133. "The Centralization of Control of Power Networks," by E. M. S. McWhirter, *El. Com.*, Vol. 13, No. 3, 1935.
134. "Supervisory Control of Traction Sub-Stations," by C. G. White, *El. Com.*, Vol. 16, No. 1, 1937.
135. "The Remote Control over Power Mains of Street Lighting, Water Heating and Other Services," by E. M. S. McWhirter, *El. Com.*, Vol. 17, No. 2, 1938.
136. "Remote Control of Power Stations," *El. Com.*, Vol. 17, No. 4, p. 399, 1939.
137. "Esterified Fibrous Insulating Materials—Part I," by A. A. New, *El. Com.*, Vol. 13, No. 3, 1935.
138. "Esterified Fibrous Insulating Materials—Part II," by A. A. New, *El. Com.*, Vol. 13, No. 4, 1935.
139. "Esterified Fibrous Insulating Materials—Part III," by A. A. New, *El. Com.*, Vol. 14, No. 3, 1936.
140. "Recent Developments in Esterified Fibrous Insulants," by A. A. New, *El. Com.*, Vol. 19, No. 2, 1940.
141. "A Modern High Voltage Cable Testing Plant," by T. N. Riley, *El. Com.*, Vol. 5, No. 4, 1927.
142. "The Condenser Cone," by J. K. Webb, *El. Com.*, Vol. 12, No. 2, 1933; "Condenser Cones for Cable

- Testing," by J. K. Webb, *El. Com.*, Vol. 15, No. 4, 1937.
143. "The Application of Styrene to H. T. Cable Systems," by T. R. Scott and J. K. Webb, *El. Com.*, Part I: Vol. 16, No. 2, 1937; Part II: Vol. 16, No. 3, 1937; Part III: Vol. 17, No. 1, 1938; Part IV: Vol. 19, No. 2, 1940.
145. "Applications of Styrene to H. T. Cable Systems," *El. Com.*, Vol. 19, No. 4, p. 141, 1941.
146. "Pioneers of Electrical Communication—James Clerk Maxwell," by Rollo Appleyard, *El. Com.*, Vol. 5, No. 2, 1926.
147. "Pioneers of Electrical Communication—André Marie Ampère," by Rollo Appleyard, *El. Com.*, Vol. 5, No. 3, 1927.
148. "Pioneers of Electrical Communication—Alessandro Volta," by Rollo Appleyard, *El. Com.*, Vol. 5, No. 4, 1927.
149. "Pioneers of Electrical Communication—Charles Wheatstone," by Rollo Appleyard, *El. Com.*, Vol. 6, No. 1, 1927.
150. "Pioneers of Electrical Communication—Heinrich Rudolf Hertz," by Rollo Appleyard, *El. Com.*, Vol. 6, No. 2, 1927.
151. "Pioneers of Electrical Communication—Hans Christian Oersted," by Rollo Appleyard, *El. Com.*, Vol. 6, No. 4, 1928.
152. "Pioneers of Electrical Communication—George Simon Ohm," by Rollo Appleyard, *El. Com.*, Vol. 7, No. 1, 1928.
153. "Pioneers of Electrical Communication—Oliver Heaviside," by Rollo Appleyard, *El. Com.*, Vol. 7, No. 2, 1928.
154. "Pioneers of Electrical Communication—Claude Chappe," by Rollo Appleyard, *El. Com.*, Vol. 8, No. 2, 1929.
155. "Peder Oluf Pedersen," *El. Com.*, Vol. 20, No. 2, 1941.
156. "Western Hemisphere Broadcast Networks. President Roosevelt's Fireside Chat of May 27, 1941," by J. W. G. Ogilvie, *El. Com.*, Vol. 20, No. 1, 1941.
157. "Selenium Rectifier Characteristics, Application and Design Factors," by C. A. Clarke, *El. Com.*, Vol. 20, No. 1, 1941.
158. "Selenium Rectifiers for Closely Regulated Voltages," by J. E. Yarmack, *El. Com.*, Vol. 20, No. 2, 1941.
159. "Sir Frank Gill, K.C.M.G., O.B.E.," by F. K. Jewson, *El. Com.*, Vol. 20, No. 1, 1941.

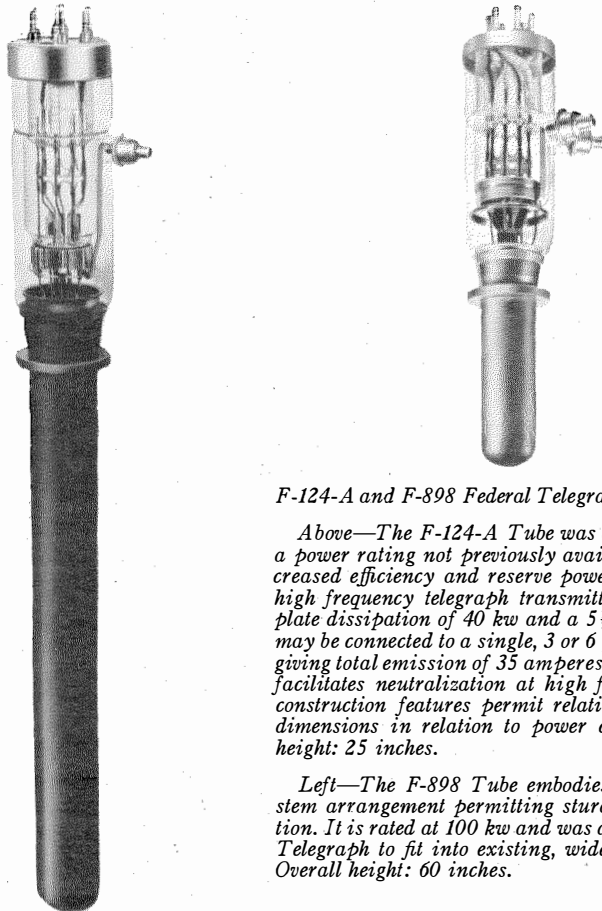

F-124-A and F-898 Federal Telegraph Company Tubes

Above—The F-124-A Tube was developed to provide a power rating not previously available as well as increased efficiency and reserve power in broadcast and high frequency telegraph transmitters. It has a rated plate dissipation of 40 kw and a 5½ kw filament which may be connected to a single, 3 or 6 phase power source, giving total emission of 35 amperes. A double grid lead facilitates neutralization at high frequencies. Unique construction features permit relatively small physical dimensions in relation to power capabilities. Overall height: 25 inches.

Left—The F-898 Tube embodies a unique filament stem arrangement permitting sturdy overall construction. It is rated at 100 kw and was developed by Federal Telegraph to fit into existing, widely used equipment. Overall height: 60 inches.

Operating Results on the New Buenos Aires–New York Twin Channel Single Sideband Short Wave Radiotelephone Link

By A. M. STEVENS, A. B., FELLOW I. R. E.

General Manager, Compañía Internacional de Radio (Argentina), Buenos Aires

IN December, 1940, Compañía Internacional de Radio (Argentina), CIDRA, an I. T. & T. subsidiary, installed a twin channel single sideband short wave equipment at its station near Buenos Aires. The results of the first year of operation have been highly gratifying from the viewpoint of improved transmission, and in addition, very substantial economies have been effected in tube replacements and power consumption. The latter is especially important under prevailing disturbed conditions inasmuch as it is necessary for Argentina to import its coal, resulting in a steady rise in power cost.

With a total a-c input of 5 kw, the new single sideband transmitter provides two good commercial channels, whereas the single channel double sideband unit formerly in service required 100 kw at full load. Thus, double the circuit capacity is obtained with 1/20th of the input power. Saving in replacement costs of vacuum tubes in the transmitter have equaled the power saving.

In the case of the double sideband equipment, commercial records over the past ten years showed an average of 94% chargeable time, i.e., the ratio of the paid time to the total talking time; the percentage of time that the circuit was available for traffic was 98%, i.e., the ratio of the commercially usable time to the total scheduled time. During the past year this record has been equaled with the single sideband low power equipment. Credit for these high percentages is due in part to the fact that conditions on the north-south path utilized are superior to those ordinarily encountered on long haul radio circuits. While CIDRA has been gratified with the improved performance with the single sideband, it has been especially pleased with subscribers' reaction, resulting from the high quality of the circuit as well as from more rapid completion of calls and prompt conveying of information to calling parties.

In addition to decreased tube replacements and reduced power consumption, economy of operation has been effected by means of the semi-automatic terminal equipment which, for long intervals, requires practically no attention from the technical operator. One attendant can easily monitor two circuits even during most unfavorable periods when wave changes, etc., are frequent, while during normal hours, he can readily handle eight to ten circuits. Moreover, the

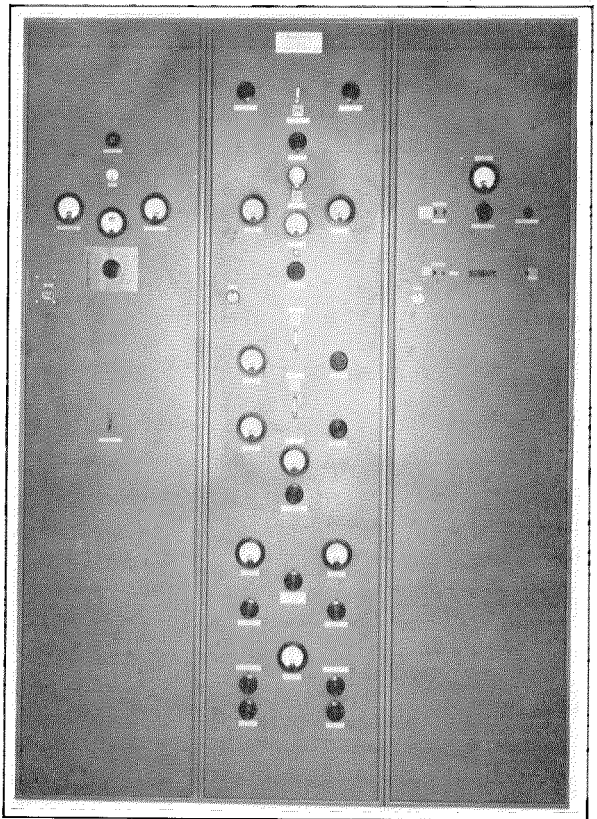

Front View of Transmitter.

Left Bay: Voltage regulator, a-c power transformer, rectifiers, and other low frequency units.

Center Bay: High frequency units, power amplifier, antenna outlet.

Right Bay: Dry rectifiers, audio frequency panels, modulators, etc.

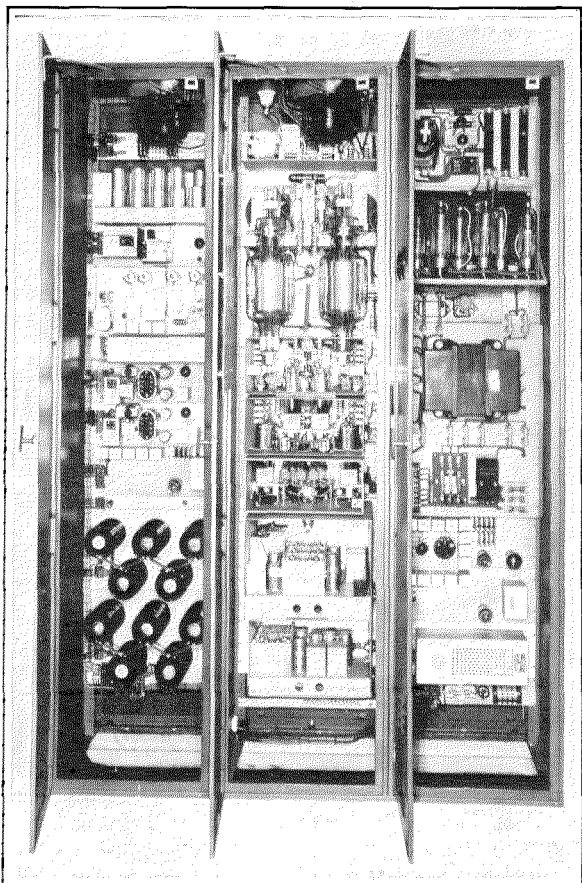

Rear View of Transmitter.

Right Bay: Voltage regulator, a-c power transformer, rectifiers and other low frequency units.

Center Bay: High frequency circuits, power amplifier, antenna outlet.

Left Bay: Dry rectifiers, audio frequency panels, modulators, etc.

automatic terminal gives better results than hand operation since automatic gain control circuits follow fluctuations in level accurately and without noticeable delay, whereas a very appreciable delay in gain control occurs when the eye and the hand attempt to keep pace with changing speech volume from two subscribers, circuit fluctuations, etc.

The transmitter includes a special panel for quick switching to double sideband operation when needed to work stations not equipped with single sideband receivers. It is also equipped with a special transmission line arranged so that the last two stages of the old double sideband transmitter can be driven as a power amplifier during poor transmission periods. The envelope peak power into the antenna with the S.S.B. unit

is normally 2 kw while, with the power amplifier, it can be boosted to 80 kw, a ratio of 40 : 1, i.e., a power gain of 16 db which is very noticeable under poor transmission conditions which usually continue for an hour or so at Buenos Aires or New York during the summer evening transition periods around 6 p.m. In general, the amplifier is used also in connection with broadcast programs to insure the highest possible signal to noise ratio.

In point-to-point transmission of broadcast programs the new equipment has given excellent results. Overall frequency runs, with the privacy equipment disconnected, have shown the audio characteristic to be practically flat within ± 1 db from 50 to 6,000 cycles. Moreover, selective fading and certain types of background noise, always heard on the double sideband circuits, are practically absent from the single sideband channels. To insure good control of the programs the second channel is rarely in traffic, the channel being used for circuit monitoring and studio contacts between the two terminals.

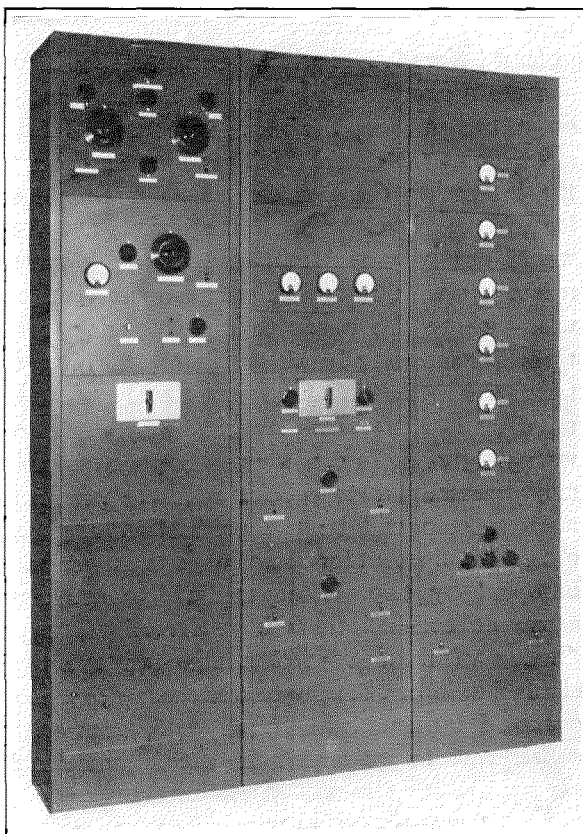

Front View of Receiver Showing Instrument and Control Panels.

On the receive side of the terminal a noise reducer is invariably in service and, when transmission conditions are poor, it gives an improvement of from 8 to 10 db in noise level. To maintain constant level into the terminal, a receiving VOGAD at the output terminals of the receiver aids appreciably in the operation of the circuits. The equipment provides two voice frequency channels 3,000 cycles wide or one voice channel and one wide band broadcast channel. Two broadcast quality channels cannot be operated simultaneously at present but it is not improbable that some solution may be found to this problem. When the two voice frequency channels are in use, one of them is displaced 2,650 cycles out from the carrier by a band spreader in the transmitter side of the terminal and, correspondingly, in the associated receiver output, the voice channel is shifted back by another unit which restores the voice channel back to its original position. Incidentally, prior to June, 1938, twin channel short wave equipment of this type was not in commercial use in the U.S.A. and, at least before 1937, had not been used elsewhere.

Since the earliest days of radio communication one of the problems has been to procure sufficient channels in the ether. With progress in the art, the increasing demand for added circuits has forced the development of equipment which would not only maintain its assigned channel frequency with negligible variation but which would carry the required intelligence in continually narrowing bands within the radio spectrum. With the history of past development in mind and with memories of long months of wrangling at radio conferences, it would appear not unreasonable to predict that the next immediate step will be the production of three channel equipment for operation in the space now occupied by two. When traffic demands and economic considerations have forced the production of three channel equipment, the two channel units can be relegated to the position now occupied by double sideband equipment with consequent improvement in the international

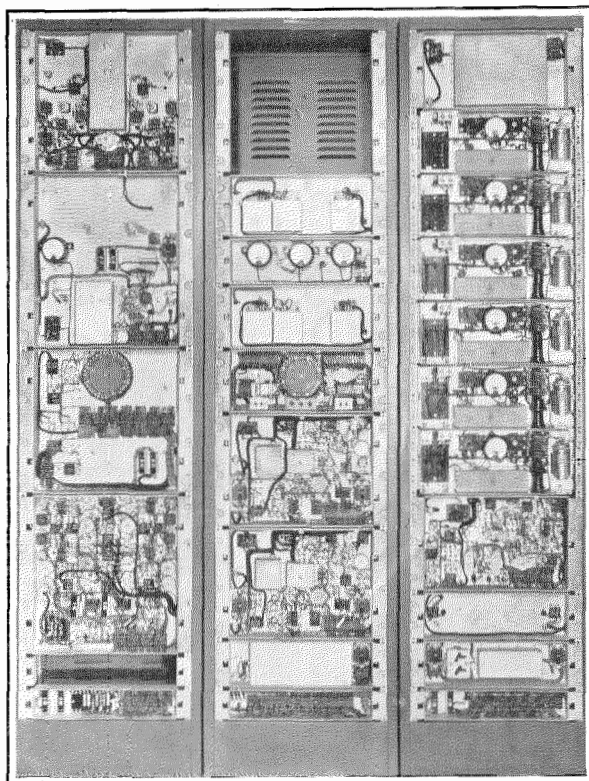

Front View of Receiver with Cover Panels Removed.

Left Bay: Upper panel contains the high frequency amplifier and first detector; second panel, the first beating oscillator; third panel, intermediate frequency amplifier and second detector; fourth panel, automatic tuning control.

Center Bay: Contains meters, monitoring control and channel amplifiers.

Right Bay: Second beating oscillator and 6 panels for rectifiers.

radiotelephone service, which has been showing a steady and healthy growth during recent years.

Since May, 1941, over 250 broadcast programs have been handled with the new equipment, of which 248 were classed "good" to "very good."

The performance of the new equipment has been so highly satisfactory that it was decided early in 1941 to install twin channel equipment on several other circuits where traffic demands and speed of service can no longer be met with a single channel equipment. The Rio de Janeiro-New York and new San Juan, Puerto Rico-New York circuits will both be supplied with similar equipment. Indications are that they will be opened for service in the relatively near future.

Durand Hospital Signaling and Communication Equipment

By W. WHITE

Compañía Standard Electric Argentina, Buenos Aires, Argentina

DURAND HOSPITAL, probably the largest institution of its kind in South America, was opened recently and is outstanding for the completeness and modernity of its building and equipment. It contains some 650 beds and is fitted with specialized facilities, such as theatres, both for clinical practice and experimental research. Signaling and communication systems, provided and installed by Standard Electric Argentina, are of a standard in keeping with the equipment as a whole. The more interesting features of these systems are described in this article.

Telephone System

Internal telephone facilities are furnished by a Bell Telephone Manufacturing Company type 7055 PABX (Fig. 1), at present equipped for 150 lines and 15 connecting circuits; the ultimate capacity is 200 lines. Code calling equipment provides a capacity of 30 codes, and code display boards are installed on all ten floors of the building. PAX conference facilities enable the Director of the Hospital to call into conference any group of predetermined individuals. Most of the telephone sets are ivory finished, thus

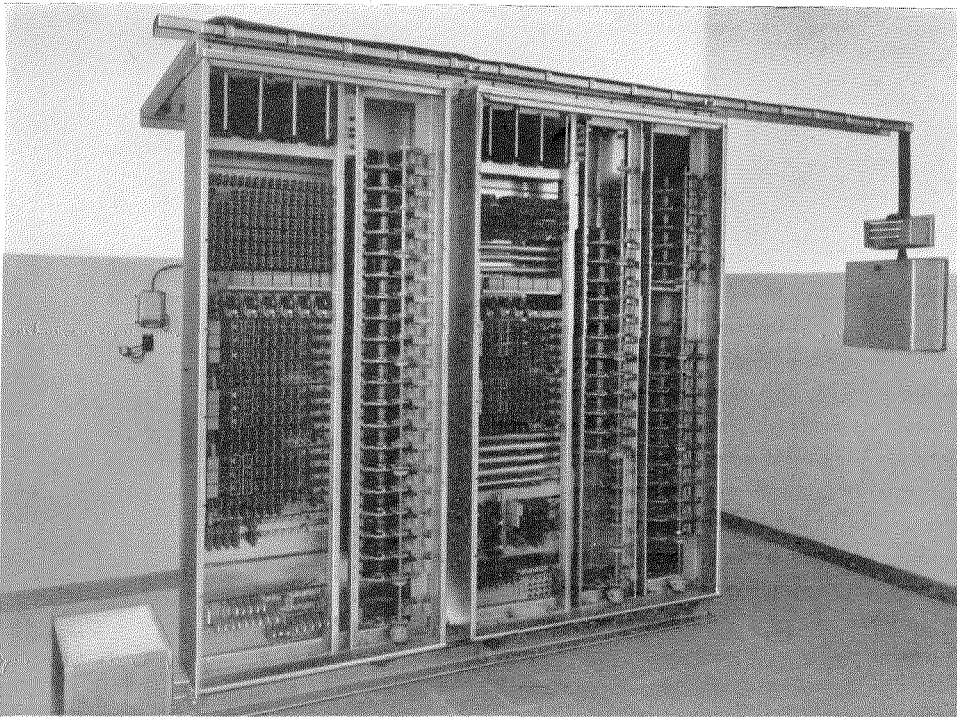

Fig. 1—Type 7055 PABX.

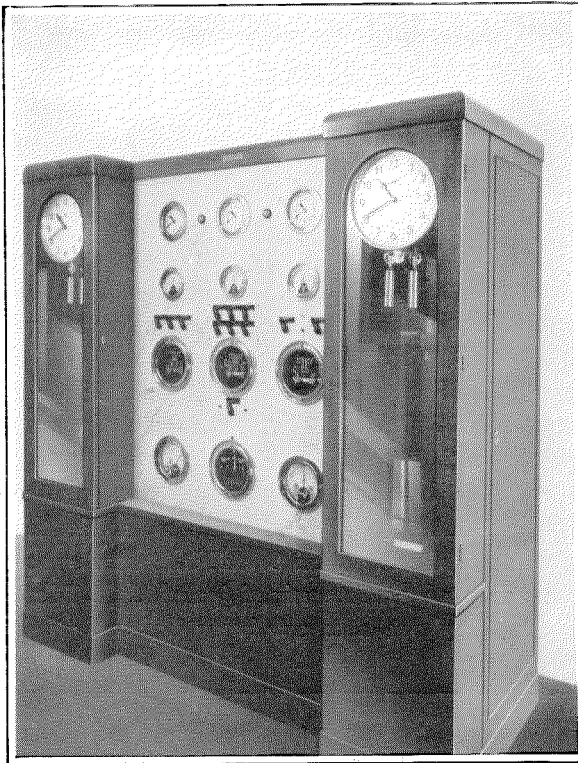

Fig. 2—Electric Clock System—Central Installation.

contributing to the immaculate appearance of the Hospital.

Electric Clock System

One hundred and thirty secondary clocks with a specified accuracy of ± 10 seconds per month for the system are installed throughout the building. They are controlled by a master clock arranged for automatic change-over to a standby master clock. The secondary clocks are divided into three individually controlled circuits. Fig. 2 gives a general view of the central installation.

Seven chronometers are provided for use in the seven operating theatres. These are seconds clocks and can be started and stopped at will; restoration to normal setting is accomplished by the operation of a foot pedal. Five date and time stamping clocks also are connected into the secondary clock circuit for control of correspondence and patients' records.

The entire system is operated from a separate 24 volt storage battery with a capacity of 12 hours of operation in case of emergency. The

battery is operated on the full float principle from a selenium type rectifier.

Patients' Calling System

This system permits patients' calling either one or both of two attendants and gives the following control indications:

A call results in lighting a lamp in the patient's room, another outside the door of his room and a group lamp designating the group of the calling room; in addition, a floor indicator is

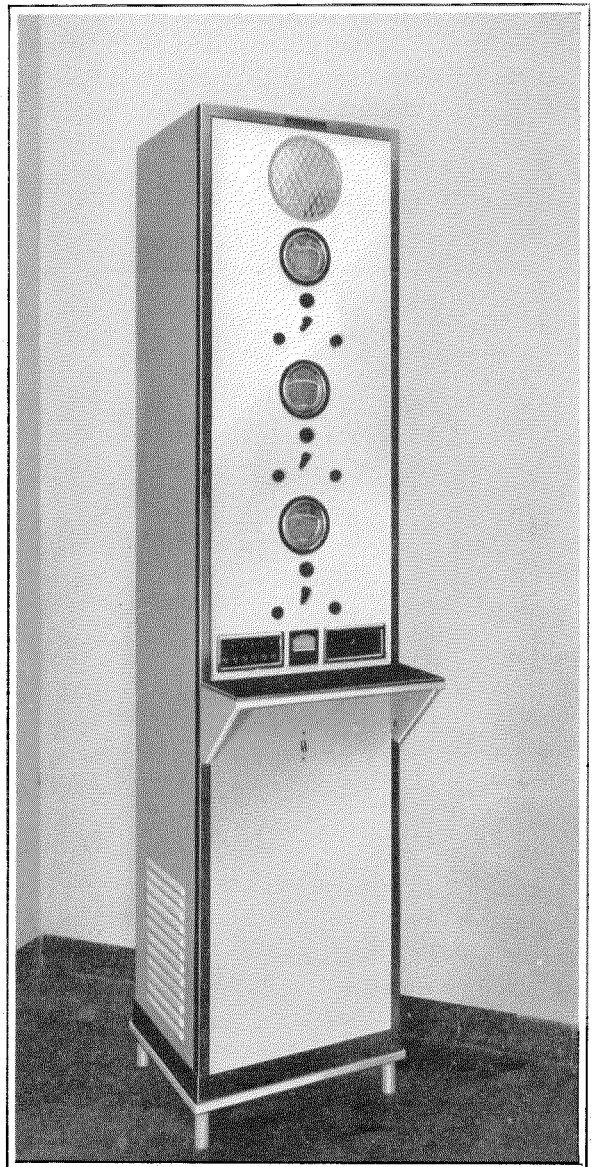

Fig. 3—Radio Receiving Equipment.



Fig. 4—Remote Temperature Indicator.

used during the night when the personnel is reduced. An audible alarm is sounded intermittently until a call is answered.

The calling system employs relay equipment of the mechanical lock-up type. The operated condition is maintained until the reset button in the patient's room is depressed, thus ensuring prompt attention to all calls.

For observation purposes all circuits are terminated in a central switchboard. As many as 40 circuits can be connected simultaneously, by means of plugs and cords, to register equipments which furnish a printed record of the time consumed in answering individual calls. Registers are individual to each circuit; the chart on which the record appears is driven from a secondary clock circuit.

Radio System

Radio facilities accessible to all rooms are provided by a centralized program distribution

system. Patients can select programs by means of a three point switch. Head phones, loudspeakers or bone conduction receivers can be used at any point. The three feed line circuits are of the constant impedance type, independent of the number of receiving equipments connected; they are fed from three all-wave receivers and amplifiers (Fig. 3), capable of supplying 60 watts to each line. The receiver caps are of a special design facilitating disinfection.

For giving instructions of a general nature to the Hospital personnel, an additional amplifier system was installed. Microphone points are provided in the Administrator's Office and in the Director's office; loudspeakers are located in the staff's quarters on each floor. A switching arrangement gives the Director control of the system even when in use from the other microphone point. The amplifier is designed to deliver 60 watts to the loudspeaker line.

Remote Temperature Indicator System

Five central indicator boards are located on different floors of the building; each board has a capacity of twenty circuits, an average of sixteen being connected at present. Thermometer elements are installed in patients' rooms, the arrangement being such that room temperatures can be read by depressing appropriate keys on the central equipment. The system operates on the Wheatstone bridge principle; the meter reading is the result of unbalances due to temperature effects on the resistance coils located in the patient's room. A small Selenium Rectifier supplies the required voltage which is regulated

within close limits by means of a ballast lamp. Fig. 4 illustrates a typical equipment.

Out-patients' Indicator System

Each consulting room of the out-patients' section is fitted with facilities enabling the physician to call any patient from a central board on which his consulting room and the patient's number are indicated. The numbers are displayed on a ground glass screen through the medium of a form of hand-operated sequence switch and a group of lamps mounted in a bakelite moulding.

Similar display boards, as illustrated by Fig. 5, are mounted over the doors of individual consulting rooms.

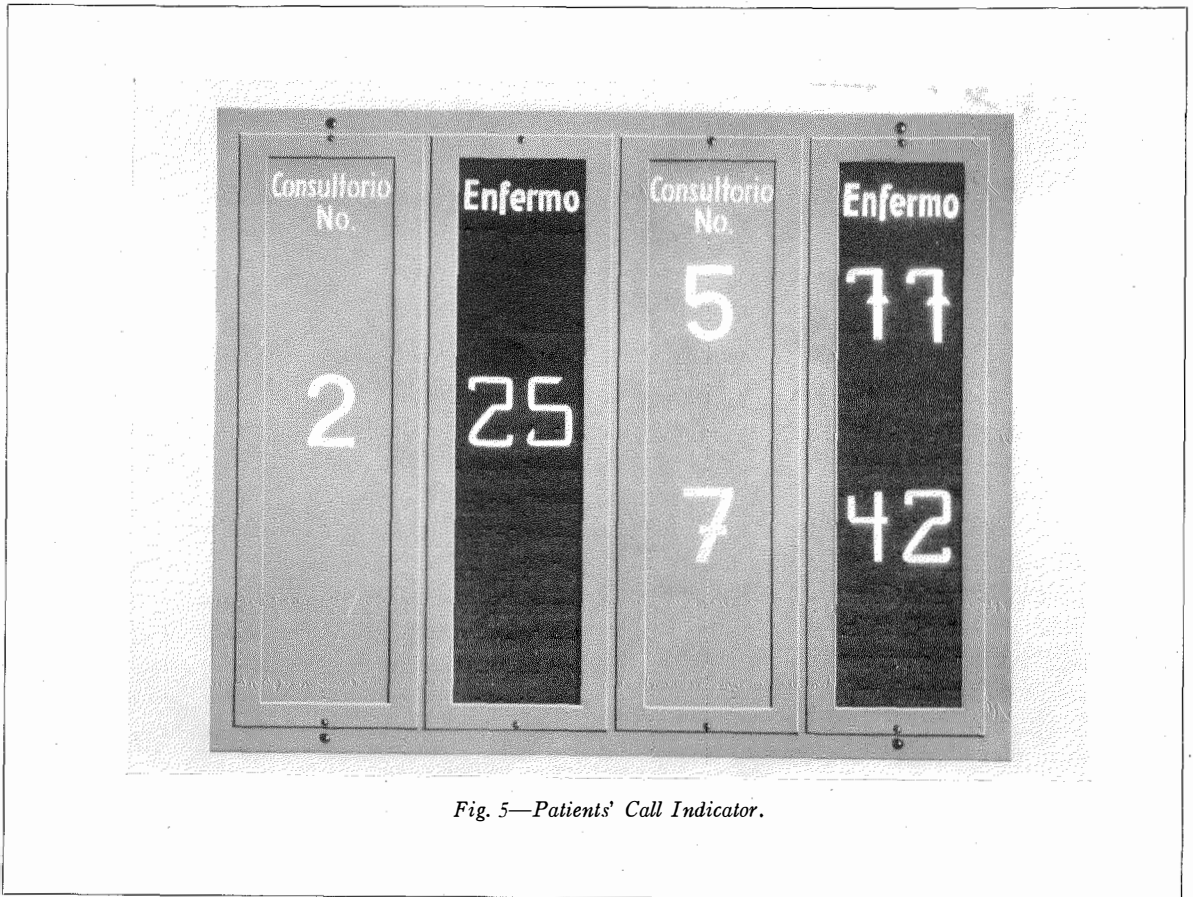

Fig. 5—Patients' Call Indicator.

Design of the Output Stage of a High Power Television Transmitter

By E. LABIN

Laboratories, International Telephone & Radio Manufacturing Corporation, New York, N. Y.

Introduction

THE Eiffel Tower Television Transmitter, built by Laboratoires Le Matériel Téléphonique in 1937 and 1938 for the French PTT Administration, operated with a peak power of 36 kw at a frequency of 46 megacycles. The modulation frequency band was 0–2.5 mc, giving a total high frequency band width of 5 mc. At that time it was, and it probably still is, the most powerful television transmitter in the world.

The present article is an abstract of a paper written in 1938 and read before the Société Française des Electriciens. The latter paper described the output stages of the transmitter with a more technical approach to this portion of the transmitter problem than was attempted in an article previously published in *Electrical Communication*.¹ In the present abstract some parts of the original S.F.E. paper dealing with special television and modulation problems have been omitted since they are now of minor interest due to the introduction of single side band transmission and an increase in the number of scanning lines. The problem of a wide band modulated output stage for ultra-high frequency service, however, appears to be of interest, and this article is, therefore, presented.

The first part of this article deals with generalities pertaining to the modulation system and the choice of output tubes. The second part contains details of the inverted amplifier circuit with the grid-reactance neutralization adopted for the transmitter, and the third part includes experimental data collected in the tests on the equipment.

¹"The Eiffel Tower Television Transmitter," by G. Rabuteau and S. Mallein, *Electrical Communication*, Vol. 17, No. 4, 1939.

I. General Output Stage Problems

1. MODULATION SYSTEM

To determine the characteristics of the output stage it is first necessary to decide on the method of modulation. The wide frequency band required leaves very little choice in this decision.

Modulation by absorption in the output circuit has been used successfully in low power applications, but for high power use the difficulties would appear to increase greatly without compensating advantages.

Modulation systems at low level considerably reduce the modulator problem, but lead to a system of wide band linear amplifiers which might be justified in single side band systems, but not for a symmetrical modulation system.

Plate modulation of the output stage is one of the best methods in normal broadcasting, where class B modulators may be used, but a transformer suitable for plate modulation with a wide frequency band has not yet been achieved.

The remaining modulation method, that of modulating the grid bias voltage of the output stage, is that used on the Eiffel Tower transmitter, as it is in almost all existing television transmitters.

It does not necessarily follow, however, that this means low modulation power. The power is not determined by the grid power requirements of the output stage, but rather by the capacity of the grid circuit to ground. This capacity is in shunt across the output of the modulator, whose output impedance at high frequency must be at most equal to the reactance of the capacity to ground. If this capacity is about 120 mmfd., and it can hardly be less due to the large physical dimensions of the circuit elements, the modulator output impedance must not be more than 500 ohms (500 ohms is the reactance of 120 mmfd. at 3 MC/S). A potential variation of about 3000

volts peak-to-peak is needed, requiring a modulator output of 2.25 kw. Since the modulator operates as a class A amplifier, a tube must be used capable of a plate dissipation of about 12 kw. The LMT tube 3053-A fulfills these conditions and was the tube used in the Eiffel Tower modulator.

The use of grid modulation adapts itself well to the need for varying the carrier to keep a constant black level. A diode at the grid of the modulating stage detects the modulating signal and causes the anode current of the modulator to vary with the average picture brightness. Thus the modulator effectively amplifies all frequencies from 0 to 2.5 mc. The plate of the modulator tube is tied directly to the grids of the output stage. The average bias of the output stage is adjusted by a bias rectifier connected between the filaments and ground.

2. DISTORTION DUE TO PLATE CIRCUIT AND CHOICE OF OUTPUT STAGE TUBE

The variation in grid voltage produced by the modulator creates side bands in the anode current in addition to the normal carrier frequency. In order that the output of these components be constant, it is necessary (but not sufficient) that the plate circuit impedance vary little over the frequency range occupied by these side bands. If the plate circuit is compared to a simple tuned circuit consisting of an inductance L , a capacity C and a parallel resistance R , the Q of the circuit will be R/Lw and deviation of df from the resonant frequency f_0 , such that

$$\frac{df}{f_0} = \pm \frac{1}{2Q} \%$$

will introduce an amplitude distortion of 3 db and a transmission delay of $\frac{.1}{4\pi df}$ seconds. That is to say, for a carrier frequency f_0 of 46 mc and a maximum modulation frequency f of 3 mc, the Q should not exceed

$$Q = 46/6 = 7.5$$

if the distortion is to remain less than 3 db and 30 millimicroseconds.

The impedance of the plate circuit at resonance is given by the formula

$$R = Q/C\omega_0 = \frac{1}{4\pi Cdf}. \quad (1)$$

With the large modulation band employed, the value of R obtained from (1) is generally less than the optimum value for the tubes. This means that in television the frequency band will determine the output impedance, and hence the type of tube to be used in the output stage.

Assuming that the output stage consists of two tubes connected in push-pull and operating in class B under peak conditions, and that the peak current available for the plate is .8 of the saturation current I_s , the saturation current necessary to obtain a peak power output of P kilowatts with a modulation band of f mc and a total circuit capacity of C mmfd. will be

$$I_s = .4\sqrt{PCf}. \quad (2)$$

For example, if a power of 36 kw and band width of 3 mc is required for an output capacity of 18 mmfd., the saturation current necessary per tube will be 17.5 amperes.

These conditions are satisfied in the Eiffel Tower transmitter by the use of two LMT tubes types 3084-A.

3. COMPLETE CIRCUIT OF THE OUTPUT STAGE

It is at first rather surprising that the above equations do not contain a term depending on the frequency of the carrier. However, other requirements must be met in order to ensure proper wide band operation beside that of a low Q output circuit:

- (a) The coupling transformer to the transmission line must have a wide band characteristic;
- (b) Neutralization must hold over the complete band;
- (c) The effects of stray coupling existing in several actual reactances should be reduced to a minimum or judiciously used.

All of these conditions depend on the relative width of the band as well as on its absolute value, and become increasingly simple to satisfy as its relative width decreases.

The output transformer will not be discussed here since its theory is well known and the relative width of the band is not even as large as that in some coupling transformers for receiver intermediate-frequency amplifiers. Similarly, the antenna and transmission line will not be considered inasmuch as an explanation of

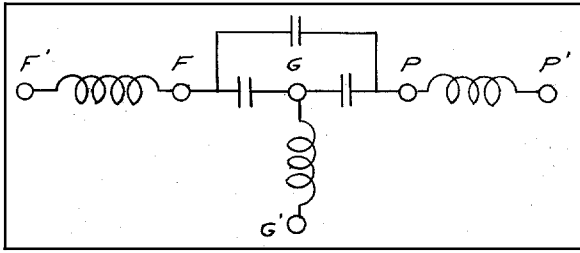

Fig. 1.

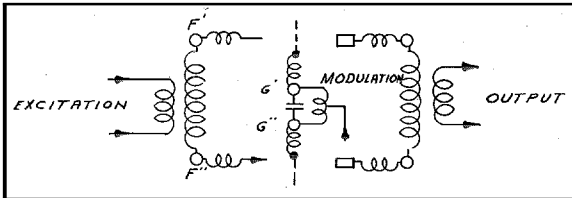

Fig. 2.

their design is considered outside the scope of this article. Points (b) and (c), however, concern the output stage itself and will be fully discussed.

We may admit that, in the frequency band around 46 mc, a triode must be replaced by a network of six reactances arranged as shown in Fig. 1. The circuit includes in addition to the three inter-electrode capacities, series inductances between the "true" terminals F , G , and P , and the accessible terminals F' , G' , and P' .

Actually such "true" terminals cannot be designated since the complete geometrical structure of a vacuum tube cannot be strictly represented by a network formed of lumped elements. The network indicated, however, represents a sufficiently good approximation for the frequency range and tube dimensions under consideration.

If a classical amplifier circuit is used with the tubes in push-pull neutralized by capacities in a balanced bridge and excited between the grids, it will be found necessary to ensure adequate neutralization over the band to compensate the grid series inductances inside the tubes by series condensers. At the high power being considered these condensers would constitute a capacitive load on the modulator that would not be negligible.

Feedback in the series inductance of the internal filament inductance is not compensated and might create difficulty in realizing the wide band operation desired.

The anode circuit capacity across the output circuit is very large, its minimum value being at least equal to C_{pg} plus $C_{pf}/2$ (without including the self capacity of the neutralizing and series condensers).

Another disadvantage of this classical circuit for grid modulation is that the modulation of the excitation is opposed to the total modulation of the stage. (When the grid becomes very negative the excitation increases and the voltage necessary to complete cutoff is larger than would be the case for a perfectly regulated excitation source.) This means that considerable excitation power must be dissipated in "swamping resistors" to improve the linearity.

II. Inverted Amplifier Circuit

1. STATIC CONDITIONS

The difficulties in neutralization and large circuit capacity indicated above lead to an inversion of the standard circuit to one in which the excitation is applied to the filaments, with modulation always applied to the grids. The system is indicated schematically in Fig. 2.

Neutralization may now be effected by balancing the plate-filament capacities, which are much lower than those between plate and grid. This system offers considerable advantage over the standard grid-excited system, but it is preferable, particularly in wide band applications, to neutralize with a suitable reactance placed between G' and G'' .

Considering only the upper half of Fig. 2, Fig. 3 is obtained, in which M represents the neutral plane of symmetry. In Fig. 3 the internal filament and plate inductances have been included in the external impedances Z and Z' . Fig. 3 is a particular case of the bridged T shown in Fig. 4, in which

- $Z_1, Z_2, Z_3,$ and $Z_4,$ represent any impedances;
- Z and Z' are the terminal impedances;
- Z_{12} is the impedance seen from terminals 1 and 2 when terminated in Z' ;
- Z_{34} is the impedance seen from terminals 3 and 4 when terminated in Z ;
- I is the current which enters the network;
- I' is the current which leaves the network.

In order to realize proper neutralization in the circuits of Figs. 2 and 3, it is necessary and

sufficient that the reactances be in such relation that in the equivalent T of Fig. 4 current I' shall be zero for all values of I (or inversely that I shall be zero for all values of I'). It may be argued that while the current from plate to ground is zero, there is a current flowing from plate to filament. This is true, but obviously no oscillation may be sustained if no current flows in the external circuit.

The condition for neutralization is equivalent to the balanced condition for the bridged T network. This condition may be easily found by applying Kirschhoff's laws or by resolving the system by the general method of determinants. The balanced condition may be written

$$Z_4 = -\frac{Z_1 Z_2}{Z_1 + Z_2 + Z_3} \tag{3}$$

When the bridge is balanced, the impedances Z_{12} and Z_{34} are independent of the terminating impedances, and their values may be obtained by assuming Z' and Z to be infinite, whence

$$Z_{12} = Z_1 \frac{Z_3}{Z_1 + Z_2 + Z_3},$$

$$Z_{34} = Z_2 \frac{Z_3}{Z_1 + Z_2 + Z_3} \tag{4}$$

If the general formulas (3) and (4) are applied to the neutralization of the inverted amplifier, we shall find that if the impedances Z_1 , Z_2 , and Z_3 are of the form:

$$Z_1 = \frac{1}{jC_1\omega}, \quad Z_2 = \frac{1}{jC_2\omega}, \quad Z_3 = \frac{1}{jC_3\omega},$$

the grid reactance Z_4 must be an inductance L defined by equation (5); and the input and output impedances are capacities C'_1 and C'_2 which are given by equations (5),

$$L = 1/K\omega^2, \quad K = C_1 C_2 / k,$$

$$1/k = 1/C_1 + 1/C_2 + 1/C_3, \tag{5}$$

$$C'_1 = C_1 C_2 / k, \quad C'_2 = C_2 C_3 / k,$$

$$C_1 = C_{fg}, \quad C_2 = C_{gp}, \quad C_3 = C_{pf}. \tag{6}$$

For the type 3084-A tube

$$C_{fg} = 25.5 \text{ mmfd.}, \quad C_{gp} = 23.5 \text{ mmfd.},$$

$$C_{pf} = 6.5 \text{ mmfd.},$$

$$k = 100/23.5, \quad K = 140 \text{ mmfd.};$$

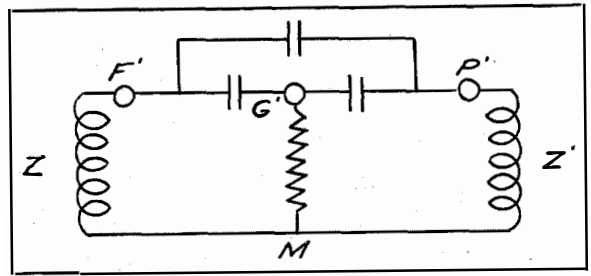

Fig. 3.

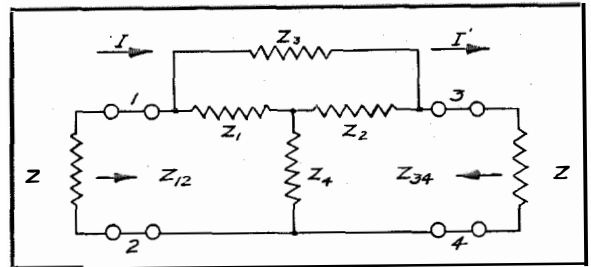

Fig. 4.

whence

$$L = 84 \text{ millimicrohenries,}$$

$$C'_1 = 1.53 C_{gf} \text{ or } 39 \text{ mmfd.},$$

$$C'_2 = 1.53 C_{gp} \text{ or } 36 \text{ mmfd.}$$

For the same tube the classical circuit gives an anode circuit capacity $C''_2 = 2.27 C_{gp}$.

The ratio $b = C''_2 / C'_2 = 1.5$ illustrates the advantage of the inverted circuit over the classical one. It shows that for an equal pass band, the plate impedance may be 50% greater, or that the output power will be about 50% more.

As a general rule, b is given by the formula

$$b = 1 + \frac{1 - C_{pf}/C_{gf}}{1 + C_{pf}/C_{gf} + C_{pf}/C_{gp}}$$

The advantage becomes greater as the plate-filament capacity decreases. The maximum value of b is 2, but in general it will be in the neighborhood of 1.5.

The neutralizing inductance L , found from equation (5) for the LMT 3084-A tubes and a carrier frequency of 46 mc, is smaller than the actual grid internal series inductance. This internal inductance is .12 microhenries and, with the necessary external leads, reaches almost .2 microhenries. It is necessary, therefore, to introduce a capacity between the grids for neutralization. This capacity has two disadvantages:

(a) The reactance between the grids formed by an inductance and capacity in series varies more rapidly than it would for an inductance alone, and neutralization is not strictly maintained over the entire frequency band. It will be seen later, however, that this effect is corrected by the inherent negative feedback present in the inverted amplifier.

(b) The condenser must carry a circulating current which is the sum of the plate and filament circulating currents and which may reach a very high value. The self-capacity of a condenser of the required physical size will be shunted across the modulator output and adversely affect its performance. At the Eiffel Tower, this condenser was replaced by a quarter-wave line terminated by a variable inductance. This combination has a capacity to ground 40 percent less than that of an equivalent condenser.

2. DYNAMIC OPERATION

Once the grid impedance has been fixed by the condition for neutralization, the dynamic operation of the unit depends not only on the excitation voltage and the plate impedance, but also on the negative feedback which is developed across the input impedance due to the flow of

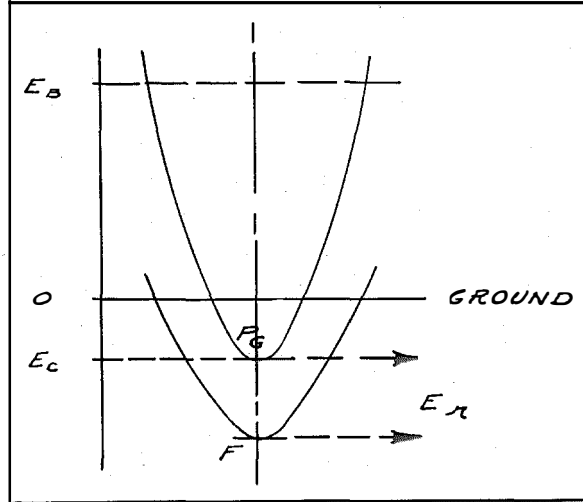

Fig. 6.

emission current through it, and on the positive feedback across the grid impedance.

Figs. 5 and 6 show the ideal variation of the voltages between the three electrodes and ground, assuming that the voltages are either exactly in phase or in phase opposition. E_b represents the direct plate voltage and $-E_c$ the direct grid voltage; the filament is assumed to be at ground potential for direct current.

The maximum plate voltage swing may be obtained as in the standard circuit by assuming that at the instant of maximum current the plate and grid are at the same potential. The filament-grid and filament-plate voltages will then be

$$V_{pf} = V_{gf} = E_r \quad \text{and} \quad V_{pg} = 0,$$

where E_r represents the residual plate voltage required to draw the required maximum current (in this case assumed as $.8 I_s$) from the filament.

It may be seen that for filament excitation the alternating plate voltage is not limited to the value $(E_b - E_r)$, but may reach E_b or even exceed it. The limiting value will be $E_b + E_c$ for an alternating grid voltage of zero.

This condition cannot be realized except for zero impedance from grid to ground and, therefore, will not be met when neutralization is effected by placing a reactance between the grids; it is, however, possible if standard bridge neutralization is used. In this case the filament excited circuit allows full use of the power supply voltage, permitting very high efficiencies

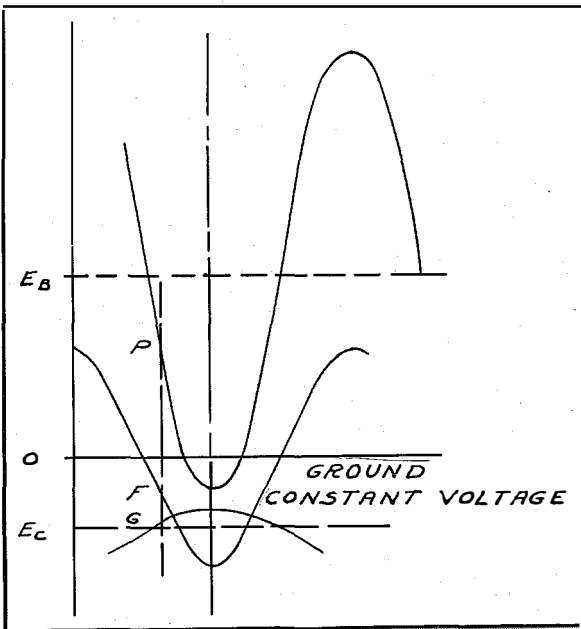

Fig. 5.

(theoretically better than 100%) if the efficiency be defined as the ratio between the high frequency power available at the output and the direct power applied to the plate. The high output is actually due to the power transferred from the excitation source to the output circuit.

The driver, in addition to supplying the excitation voltage, also feeds power to the output load through the resistance of the output tubes.

Another reason for the need of large excitation power is that, in the inverted amplifier, the emission current flowing through the filament circuit impedance creates a negative feedback so that additional power is required to maintain the voltage E_r between filament and grid. The excess power will depend upon the input impedance of the output stage. Due to this negative feedback, the impedance in the filament circuit plays an important role in determining the passband of the amplifier.

As an illustration of the way in which reactions are balanced the circuit of Fig. 5 will be considered. In this case the amplifier is neutralized with a grid reactance so that the impedance between the grids is appreciable, and it will be shown that an operating condition may be set in which the various reactions practically cancel out. The result is that the plate current depends essentially only on the excitation voltage and varies with frequency as does this voltage.

We shall consider E_x as the excitation voltage present when no anode current flows, I_1 the fundamental frequency component of the plate current, and Z_{fm} and Z_{pm} , respectively, the impedances between filament and ground and plate and ground, which will be assumed as zero for the harmonics of I_1 . We will designate by m_f and m_p , respectively, the portions of the filament and plate voltages which are across the grid impedance.

When the bridged T is balanced, the components m_f and m_p may be calculated by the formulas:

$$m_f = -C_{pf}/C_{p0}, \quad m_p = -C_{pf}/C_{fg}. \quad (7)$$

From the definition of m_f and m_p we may also obtain the formula

$$V_g = V_p m_p + V_f m_f, \quad (8)$$

where the single subscripts g , p , and f indicate the voltage from the tube element to ground.

Further, the operating condition of the stage is determined by the control voltage and tube characteristics so that the plate current is a function of

$$V_{gf} + \frac{V_{pf}}{\mu}$$

only, where μ is the amplification factor of the tube.

The following equations are then obtained directly:

$$\begin{aligned} V_p &= -(E_x - I_1 Z_f), \\ V_p &= -I_1 Z_p, \\ V_{gp} &= V_g - V_p, \\ V_{pf} &= V_p - V_f, \end{aligned} \quad (9)$$

and the formula for the control voltage becomes

$$V_{gf} + V_{pf}/\mu = E_x(1 - m_f) + E_x/\mu - I_1[Z_p(m_p + 1/\mu) - (m_f - 1 - 1/\mu)Z_f]. \quad (10)$$

Equation (10) indicates that it is possible to adjust the ratio of anode and filament impedances in a manner such that the control voltage will not depend upon the anode current. This condition of reactance compensation is obtained when the coefficient of I_1 in equation (10) is reduced to zero, or when

$$\frac{Z_f}{Z_p} = \frac{m_p + 1/\mu}{m_f - 1 - 1/\mu}. \quad (11)$$

For the 3084-A tube, the values found for m_f and m_p from equation (7) lead to the equation

$$Z_p = 5Z_f. \quad (12)$$

Thus the variation of the filament impedance with frequency follows the same law as the plate circuit impedance variation, i.e., the Q 's of the two circuits should be equal. This may be accomplished by appropriate loading of the input circuit.

Equation (12) must be considered an approximation since the reactance in the grid circuit does not ensure neutralization over the whole frequency band. The values of m_f and m_p apply only to the carrier condition, whereas variation actually occurs over the entire frequency band.

If the variations in these two factors are sufficiently slow, it is possible to fulfill the conditions of equation (11) by detuning Z_{fm} and Z_{pm} slightly, even when the reactance between

the grids is not exactly that imposed by equations (5).

For a given grid reactance, the relative regulation of the filament and plate impedances may be changed to expand or contract the passband of the stage as desired. It must be understood, however, that this will be accompanied by a corresponding decrease or increase in output power.

A more complete theory of the amplifier adjusted as shown above may be developed by expanding coefficients m_f and m_p to include their variation with frequency. The calculations, however, are laborious and it would appear preferable to use simply the approximate solution given above. This is entirely adequate, since it allows an estimate of the direction of variation of the various elements. Furthermore, a more precise theory giving the exact impedance values would be somewhat illusory considering the initial approximations and the accuracy with which the tube reactances may be determined.

The detuning of the plate and filament im-

pedances allows a constant modulation depth at all frequencies, but has a tendency to introduce delay distortion.

In the foregoing discussion only the frequency response of the modulated amplifier has been considered.

The linearity of modulation is less important in television than in speech and program broadcasting, but it is still advisable to be able to reduce the carrier to zero without the necessity for excessive modulating voltage. This zero carrier condition corresponds to the base of the synchronizing pulses in the European standards and to a full white image in the American standards.

The excitation of the filament circuit through a quarter-wave line allows linearity to be approached in the low carrier region inasmuch as the excitation has a tendency to decrease at the same time the plate current decreases. This is due to the fact that a quarter-wave line inverses impedances so that, when the input impedance at the filaments increases, the load on the driver

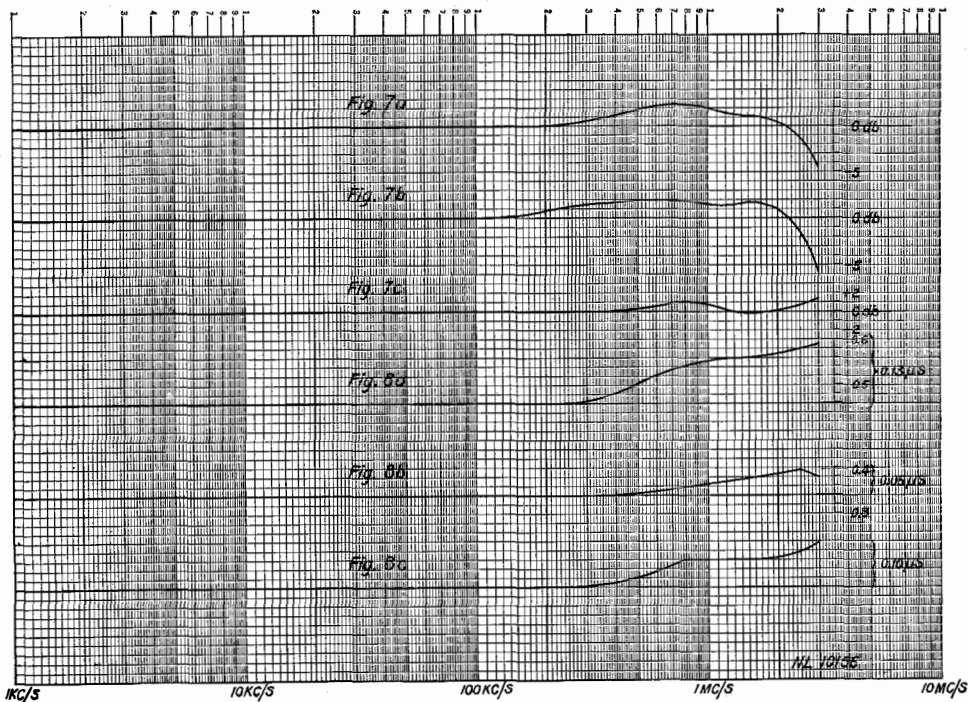

Figs. 7 and 8.

also increases. In the Eiffel Tower transmitter, linearity is equally good at both ends of the modulation characteristic despite the use of grid modulation. The result is that the transmitter may be used equally well for transmission with positive or negative systems (European or American standard).

III. Experimental Results

The following curves indicate the distortion introduced in the modulated amplifier:

Fig. 7a shows the frequency-amplitude response characteristic of the complete transmitter measured between the input terminals of the modulator and the output terminals of a detector coupled to the transmission line feeding the antenna. The errors introduced by the detector are negligible for modulation frequencies up to 3.5 megacycles.

In this figure, zero level corresponds to 50 percent modulation of the carrier. The input level to the modulator is .5 volts rms.

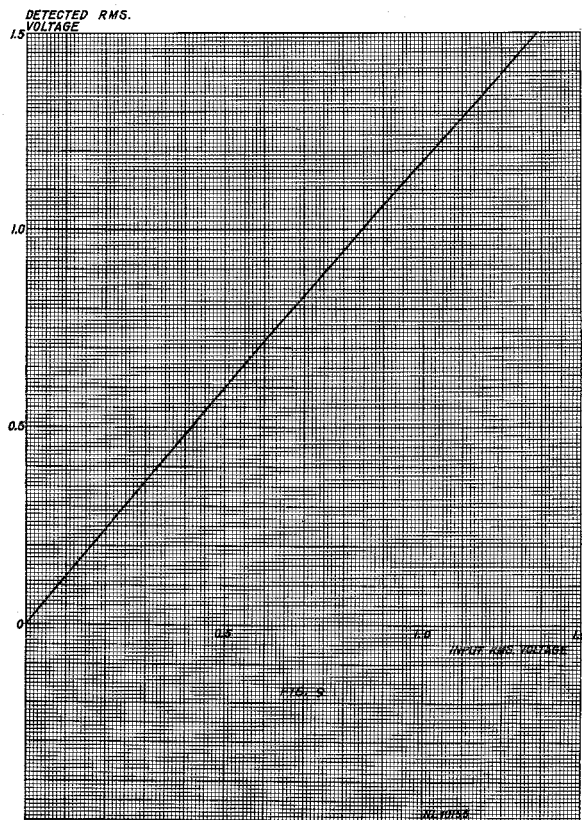

Fig. 9.

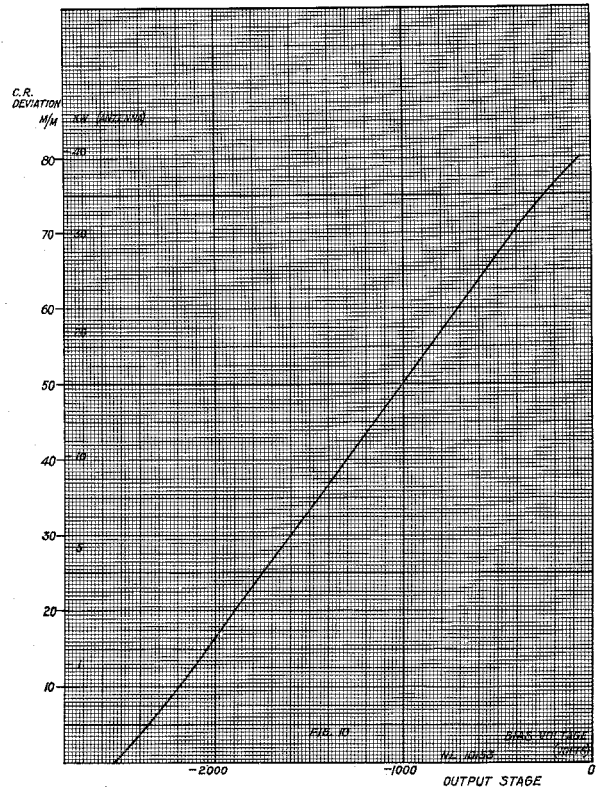

Fig. 10.

Fig. 7b shows the frequency response of the modulator taken between its input and output terminals i.e., between the grid of the modulated amplifier and ground. The output voltage is measured through a calibrated capacity potentiometer. The input level is the same as for Fig. 7a. The zero output level corresponds to the level obtained at 100 kc, about 400 volts rms.

Fig. 7c is obtained by taking the difference between the curve for the complete transmitter and the modulator, and represents the response curve of the output stage alone. It will be seen that this curve is substantially constant, the greater part of the amplitude distortion occurring in the modulator. (The modulator was designed in 1937 for a 2 mc frequency band.)

Fig. 8 gives similar information for phase distortion, indicating the total transmission time between the input of the modulator and the output of the detector coupled to the transmission line. Curve b shows the transmission time for the amplifier alone. The difference between a and b gives curve c, the characteristic of the output stage alone. The difference in the average delay

in curves 8a and 8b comes from the fact that additional transmission lines between test instruments were used so that there was a constant difference in the propagation times. In curve 8c the zero level of delay has been placed at the 100 kc value.

Tests were made both at the output of the transmitter and the output of the modulator using the LMT phasemeter with a constant input level of .5 volts rms. This phasemeter measures the angle between two vectors at a frequency of 2000 cycles. A local oscillator is used to beat with the frequency to be measured and adjusted so that the beat frequency is always 2000 cycles. The transmission time is obtained from the angular shift by dividing by the frequency.

The angles may be measured to about one degree so that for transmission times below about .5 microseconds, the accuracy below 100 kc is insufficient. However at these low frequencies direct measurement of the phase angle may be made.

A comparison of curves 8a and 8b shows that the increased delay at high frequencies is largely due to the output stage. It may be stated then

that the modulator is largely responsible for the amplitude distortion and the output stage for the phase distortion. This distortion in the output stage is due to the grid reactance and should be compensated in the modulator if it cannot be tolerated.

The curve of Fig. 9 indicates the variation in detected output voltage as a function of input voltage to the modulator. The curve of Fig. 10 is a modulation curve of the output stage, obtained by varying the bias and measuring the output on an oscilloscope coupled to the transmission line. The two curves are substantially straight.

The linearity of the curves at the low-level end is remarkable for a grid-modulated stage. This is due to the quarter-wave line coupling the input to the driver stage.

Measurements of the rms distortion entirely confirm the curves of Figs. 9 and 10 since, for 80 per cent modulation at a frequency of 10 kc, the harmonic content is only 2.1 percent. This distortion does not exceed 3.2 percent at any modulation frequency in the passband.

The Conversion of Buenos Aires City Network to Automatic

By C. G. BARKER, H. E. D. GARNHAM and W. WHITE

United River Plate Telephone Company, Limited, Buenos Aires, Argentina

POLITICALLY, Buenos Aires the world's seventh largest city, is the Federal Capital of the Argentine Republic. With boundaries fixed by law, it is governed by a Mayor appointed by the President of the Nation and an elective Municipal Council. Industrially and commercially, it is the great metropolis, the country's leading seaport, its principal railhead, the distributing center for a vast back-country, the concentration point of most of the business as well as most of the urban population: a cluster of many smaller cities, towns and villages, each independently governed, but all grouped about and dependent for their existence and their development upon the Federal Capital, which is the core of the metropolitan district.

Telephonically, the frontiers which legally confine the Federal Capital insofar as the public administration is concerned do not exist with respect to service. Avellaneda, the largest and most industrial of the suburbs, is separated from the Capital but by a narrow though navigable stream, crossed by many bridges. Other suburbs are literally only just across the street from the Capital.

An 18-year task of converting the system serving the Federal Capital and Avellaneda from manual to automatic working, in the face of rapid growth of the city as a whole and of certain of its areas in particular, of the demand for more ample telephone facilities in all sections, and of a world-wide financial depression followed by war abroad, is drawing to a close. Early in 1942 it is expected that the conversion will be completed, and only dial telephones will exist within the Federal Capital and Avellaneda. It is therefore opportune to review the work that has been done in its chronological sequence, and note the interesting and important facts to be derived from that extensive practical lesson.

To appreciate the complex problem confronting the United River Plate Telephone Co. Ltd., an I. T. & T. subsidiary, it must be borne in mind

that when the plan for conversion to automatic was initiated there were only 55,000 stations in the area thus to be converted, whereas at the completion of the task there will be approximately 270,000 stations connected to 25 automatic exchange buildings, as against 16 manual exchanges in 1923. At the same time, a manually operated suburban system has increased from 5,100 stations connected to 22 exchanges in 1923, to 31,000 stations connected to 32 offices in 1941. The expansion of this latter service has constituted a continuous and constantly growing inter-office trunking problem and has added substantially to the volume of traffic flowing in and out of the Federal Capital throughout the conversion period.

The Buenos Aires automatic system serves a thickly built-up urban area of 238 square kilometers with a population of 2,860,000, including the adjacent industrial suburb of Avellaneda previously mentioned. The entire metropolitan telephone area, i.e., the Federal Capital proper and its suburbs, embraces 1,500 square kilometres with a total of 3,750,000 inhabitants. A plan of this area is shown in Fig. 1. This plan shows by a heavy line the separation between the automatic capital network and the manual suburban network. The various classes of service given in each exchange area are indicated as follows:

Automatic in gray, C.B. shaded, Magneto in white and one rural automatic area is cross-hatched. The 10, 20 and 30 km circles are drawn from Cuyo as a center to give an idea of the size of the area. Main trunk routes are shown in full line where underground, and dotted where aerial. Each office area is identified by a two letter abbreviation and the characteristic which is dialed to reach it. Office locations in the network are shown by a small circle; the offices indicated by a small square near the 30 km circle are provincial offices to which toll fees are charged.

The modernization of the Buenos Aires telephone system and its simultaneous expansion to

meet annual requirements are of more than local significance, not only because of the importance of the Capital in the life of the nation, but also because it is the concentration point and switching center for most of the national and international long distance service. While these outside services in general function the same regardless of whether the local service in the Capital is manual or automatic, it is, nevertheless, obviously more difficult to convert the local system in a city which is not only the point of origin and destination of the majority of the long distance and international traffic, but which is also the hub of the entire communications network.

Initiation of Automatic and 1924 Study

The conversion of Buenos Aires was commenced by the inauguration of Barracas, Corrales, Retiro and Plaza offices and the transfer of some 6,000 manual subscribers.

On January 1, 1923, the Buenos Aires Capital network, including Avellaneda, contained some 50,000 manual subscribers served from 15 manual exchange areas as indicated by the heavy line boundaries of Fig. 2. It had previously been decided for economic reasons to relieve the existing congested C.B. offices by the addition of automatic step-by-step type offices. This class of office had already been working satisfactorily for

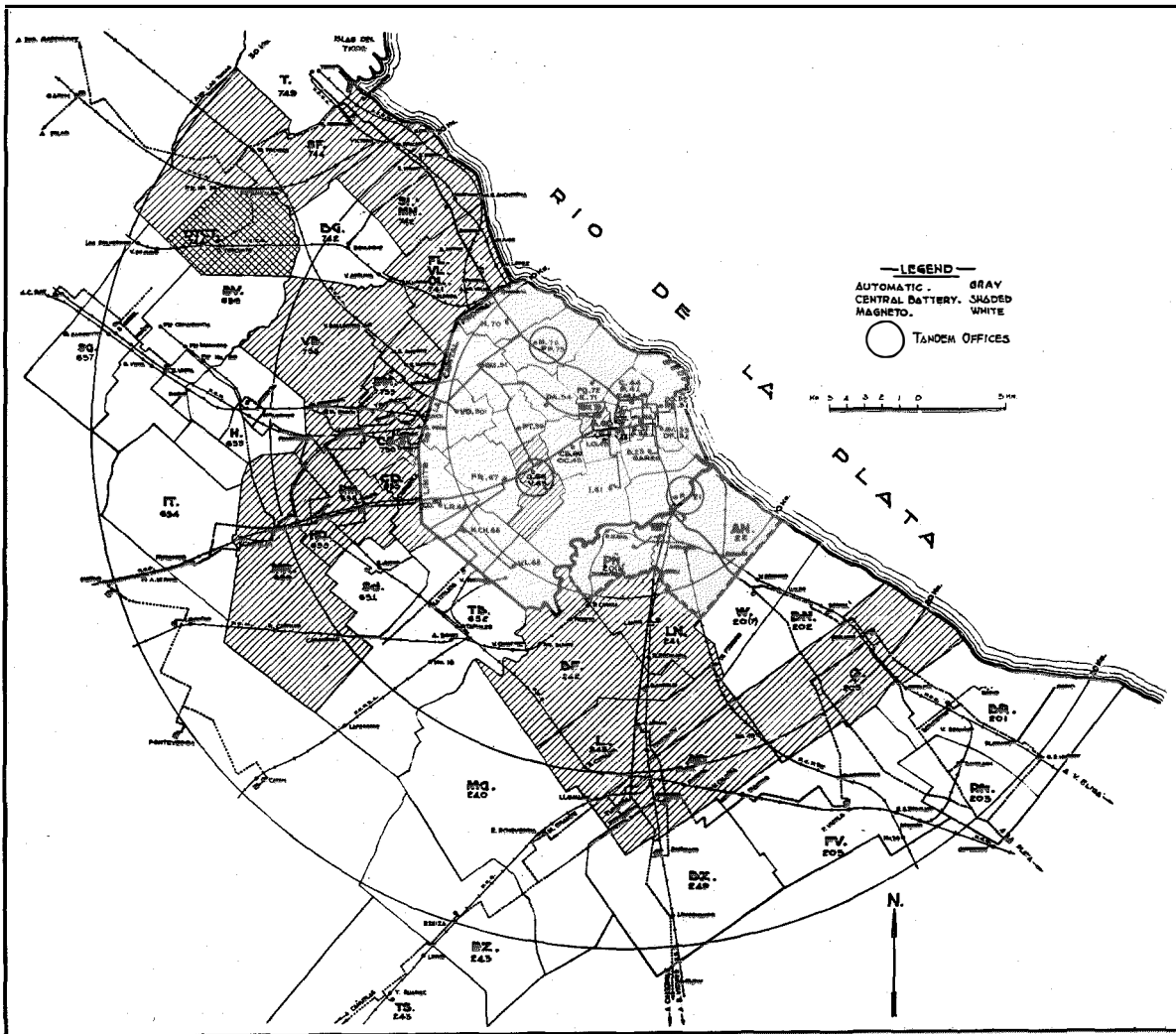

Fig. 1—Fundamental Plan Buenos Aires and Suburbs. Office locations and boundaries, main trunk routes and class of service are indicated.

some ten years in Rosario and Córdoba, two important provincial cities, in connection with which some staff had been trained in automatic working.

A ten-year study was made covering the period up to January 1, 1935, the main purpose of which was to determine the most economical layout for the conversion of the whole Capital to automatic. At this time the Mitre C. B. area was very large and had been growing at the rate of approxi-

mately 14 percent per annum during the previous ten years. It had reached its maximum capacity, and studies were made to determine the most economical way to subdivide this large area, resulting in the arrangement indicated in Fig. 2. This plan shows the Capital exchange locations and boundaries at 1923, also those proposed under the new arrangement at 1935.

Economic studies showed that the residue of the Mitre area could be more economically di-

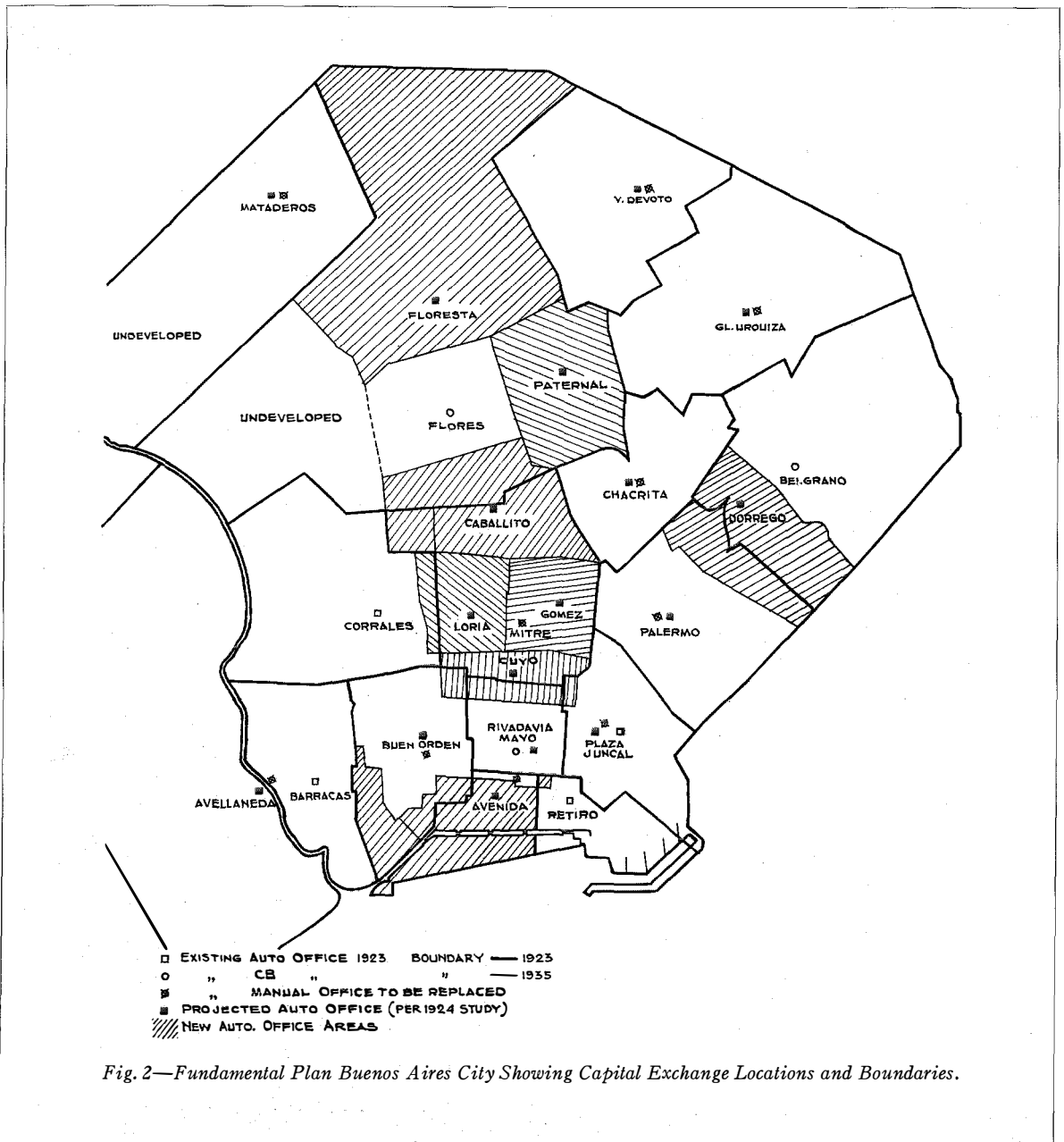

Fig. 2—Fundamental Plan Buenos Aires City Showing Capital Exchange Locations and Boundaries.

vided into two offices, and it was therefore planned to replace the remaining part of Mitre at a later date by Loria to the south and Gómez to the north. In addition to Mitre, several offices did not have sufficient capacity to carry the estimated growth for more than a few years. As a result of districting comparisons, the placing of the following offices in relation to existing offices was recommended:

- Cuyo between Rivadavia and Mitre;
- Caballito between Mitre and Flores;
- Floresta on the far side of Flores;
- Paternal between Flores and Urquiza;
- Dorrego between Belgrano and Palermo.

The Retiro office had been opened in 1923 as the first step of the division of the Avenida area into two parts and it was proposed to find a site near Plaza Mayo, which was the new telephone center for the modified Avenida area, and place a large building and 20,000 lines of automatic at this site in order to eliminate the existing office in Avenida de Mayo 761, which was structurally unfit to carry automatic loads.

In the case of the Rivadavia-Mayo exchanges, a third unit was planned to be placed in the lot adjoining the Libertad C.B. office. Libertad subscribers were transferred to Mayo and the Libertad building was demolished and a new building erected to house the third automatic unit and engineering offices. The first section of the building on the corner of Rivadavia and Libertad had been rebuilt and was housing the Rivadavia C.B. office. The Mayo automatic office was inaugurated on the second floor of this building in 1924, a few months before the study was started.

In order to relieve Buen Orden, it was recommended to divert part of this area to Avenida and part to Barracas, where a new exchange had been opened, thus permitting the conversion of Buen Orden to be deferred to a later date when other more urgent conversions had been completed.

Belgrano, Flores and Rivadavia were relatively new N^o.1 C.B. exchanges and it was therefore planned to retain them as manual exchanges throughout the entire ten-year period covered by the study. The conversion of the Capital was to be 88 percent completed on January 1, 1935. The progress of the conversion

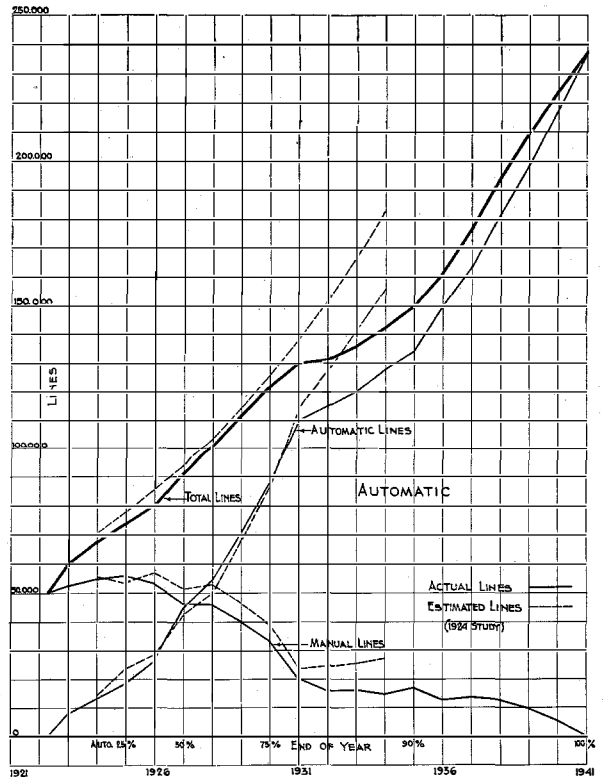

Fig. 3—Conversion of Buenos Aires to Automatic—Proportion of Automatic Lines Each Year.

compared with the study estimate is shown in Fig. 3, and it will be seen that for the first seven years the estimate was closely realized; but thereafter, due to the economic crisis, the anticipated rate of development and conversion was not maintained, almost all expenditure being limited to projects covering immediate station gain.

Transmission conditions were improved by the conversion to automatic, since the Stone 200 × 200 feed with 48 volt battery gives slightly less loss than the Hayes 24 volt feed with 22 × 22 ohm repeating coils; and further, the larger areas were being reduced in size, thus shortening the long subscribers' loops. Solid back transmitters were in use at the time the 1924 study was made; after the 323-W. transmitters were introduced about 1929, a new transmission study was made covering both Capital and suburbs.

Modification of Plan

During the years 1925 to 1930, the following modifications were made in the plan:

- 1) In 1926 an office was opened in Liniers to the north of Floresta where, due to electric traction, paved roads, motor-bus service and a Municipal housing scheme, mushroom growth had developed. The Liniers area before the office was opened in May, 1926, had 86 subscribers, and approximately 1,143 five and a half years later (December, 1931).
- 2) In 1930 a relief exchange to Belgrano was placed on the north side of the office in Nuñez, instead of on the south side, as shown under "Dorrego" in the original study (Fig. 2).
- 3) In the same year the conversion of Belgrano and Flores to automatic was started by placing step-by-step equipment in the existing C.B. buildings.

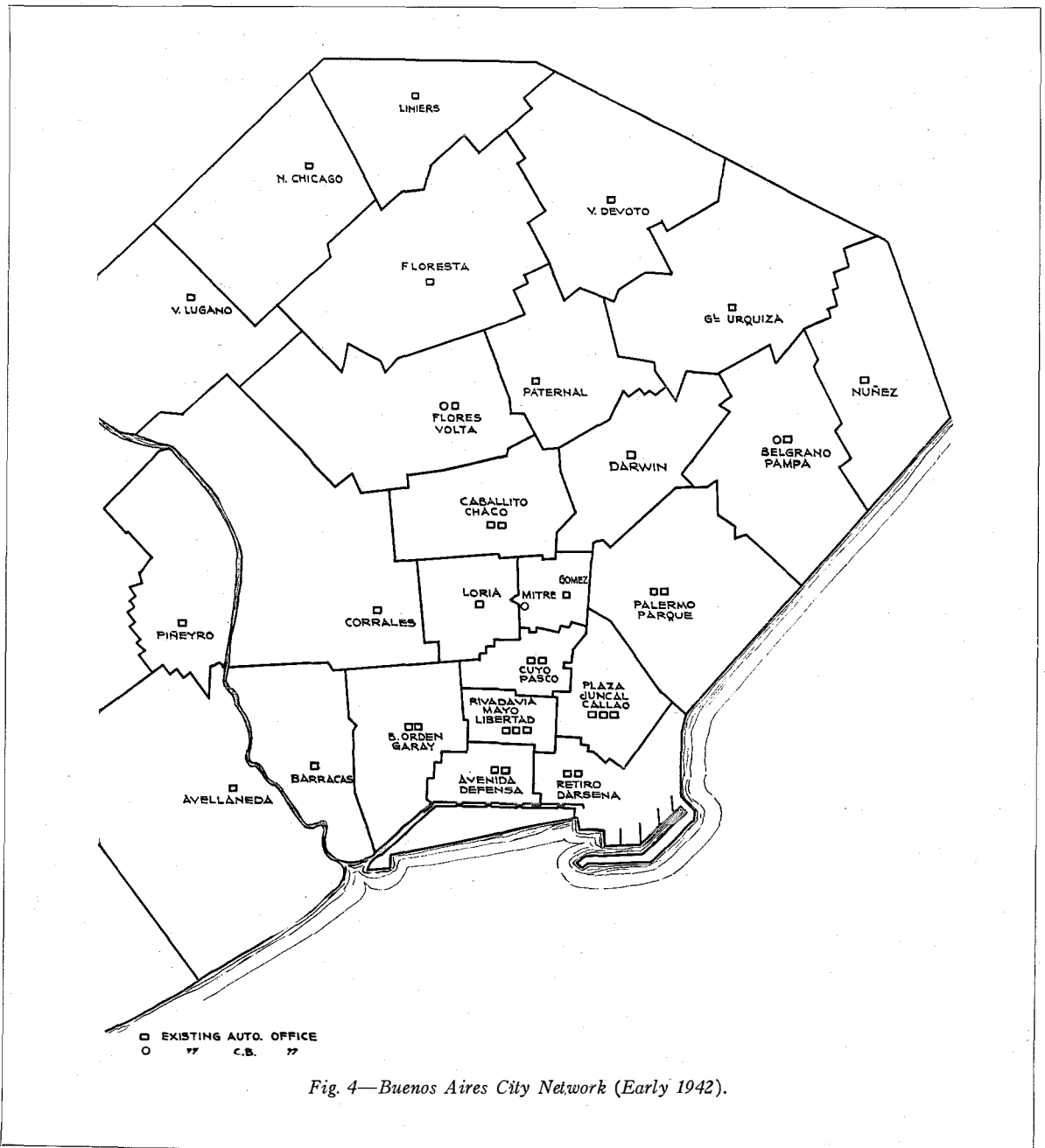

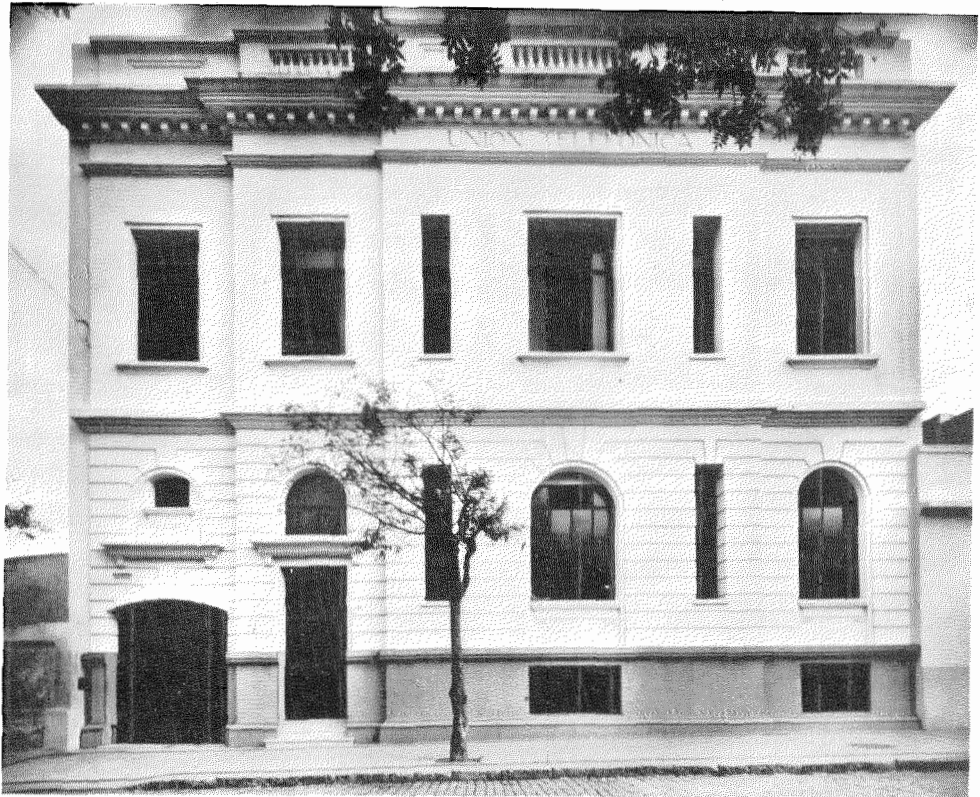

Fig. 5—Gómez Exchange, Buenos Aires.

- 4) Piñeyro satellite office in Avellaneda was opened in 1936.
- 5) Villa Lugano satellite office was opened in 1940. The network as it is and will be when the conversion is 100 percent complete is shown in Fig. 4. It will be noticed that it is very similar to that outlined in the original plan shown in Fig. 2.

Progress

In 1927, five new automatic exchanges were opened under the plan at Cuyo, Caballito, Floresta, Avellaneda and Palermo; at the end of that year, 20,000 lines were working in these exchanges, consisting of 15,000 manual lines cut-over and 5,000 new lines added during the year, bringing the percentage of automatic lines in the Capital on December 31, 1927, to 50 percent of the total.

After opening Villa Devoto and the large Defensa Administration building in 1928, and inaugurating the Avenida automatic unit in the latter building in January, 1929, another heavy year occurred in 1930, when six more automatic units were inaugurated, three in existing buildings at Belgrano, Flores and Urquiza, and three in new buildings at Loria, Paternal and Nuñez.

The lines cut-over during 1930 were 12,230, and at the end of the year the conversion was 75 percent completed. Since that date, due to the economic crisis, the conversion was slowed down: Buen Orden was cut-over in 1931, Liniers in 1936, Nueva Chicago in 1937 and Rivadavia in 1939. In 1940, the Gómez building was completed and the new Gómez unit inaugurated. This modern building, shown in Fig. 5, will house some 30,000 lines on two floors; an additional story may be added in the future. This

office takes the remaining C.B. lines from Mitre, and also provides relief to surrounding areas. As previously mentioned, it is expected that the conversion will be completed early in 1942.

Numbering Scheme

In 1923 it was anticipated that the number of lines in the Capital would exceed 100,000 in five years, and any initial use of a 5-digit numbering

CAPITAL

200,000 Group		300,000 Group		400,000 Group		500,000 Group		600,000 Group		700,000 Group		800,000 Group		900,000 Group	
Code	Office	Code	Office	Code	Office	Code	Office	Code	Office	Code	Office	Code	Office	Code	Office
20	South East Auto Conc	30		40		50	V.Devoto	60	Caballito	70	Nuñez	80	Time Service	90	Directory
29		39		49		59	Paternal	69		79	Gomez	89		99	Test Desk
28		38	Mayo	48	Pasco	58		68	N.Chicago V.Lugano	78		88		98	*
27		37	Rivadavia	47	Cuyo	57		67	Floresta	77		87		97	—
26	Garay	36		46		56		66	Flores	76	Belgrano	86		96	Complaints
25		35	Libertad	45	Loria	55		65	Wes Auto Conc	75	North West Auto Conc	85		95	Ring Back
24	South Auto. Conc. Barracas	34	Defensa	44	duncal	54	Darwin	64	Liniers	74	North Auto. Conc	84		94	Repairs
23	B.Orden	33	Avenida	43	Chaco	53		63	Volta	73	Pampa	83		93	—
22	Avellaneda	32	Darsena	42	Callao	52		62	Mitre C.B.	72	Parque	82		92	Toll
21	Barracas	31	Retiro	41	Plaza	51	G.Urquiza	61	Corrales	71	Palermo	81		91	—

* CO'S P.B.X. = 37.911

SUBURBS

SOUTH		SOUTH		WEST		NORTH		NORTH-WEST	
200		240	M. Grande	650	(680 N.C.)	740		750	
209		249	Burzaco	659	Morón	749	Tigre	759	
208	{ Pineyro V. Alsina	248		658	{ R. Mejia Haedo	748		758	V. Ballester
207		Wilde	247			657	S. Miguel	747	757
206		246		656	B. Vista	746		756	
205	F. Varela	245		655	Hurlingham	745		755	S. Martin
204		244	Adrogué	654	Ituzaingo	744	{ S. Fernando D. Torcuato	754	NOTE
203	{ Ranelagh Quilmes	243	{ Ezeiza Lomas Temperley T. Suarez	653	Ciudadela	743			
202		Bernal		242	Banfield	652	Tablada	742	{ S. Isidro Martinez Boulogne
201	Berazategui	241	Lanus	651	Sandusto	741	{ Florida V. Lopez Olivos	751	

Fig. 6—Buenos Aires Fundamental Plan 6-Digit Numbering Scheme—Characteristic of Each Office Unit, 1941.

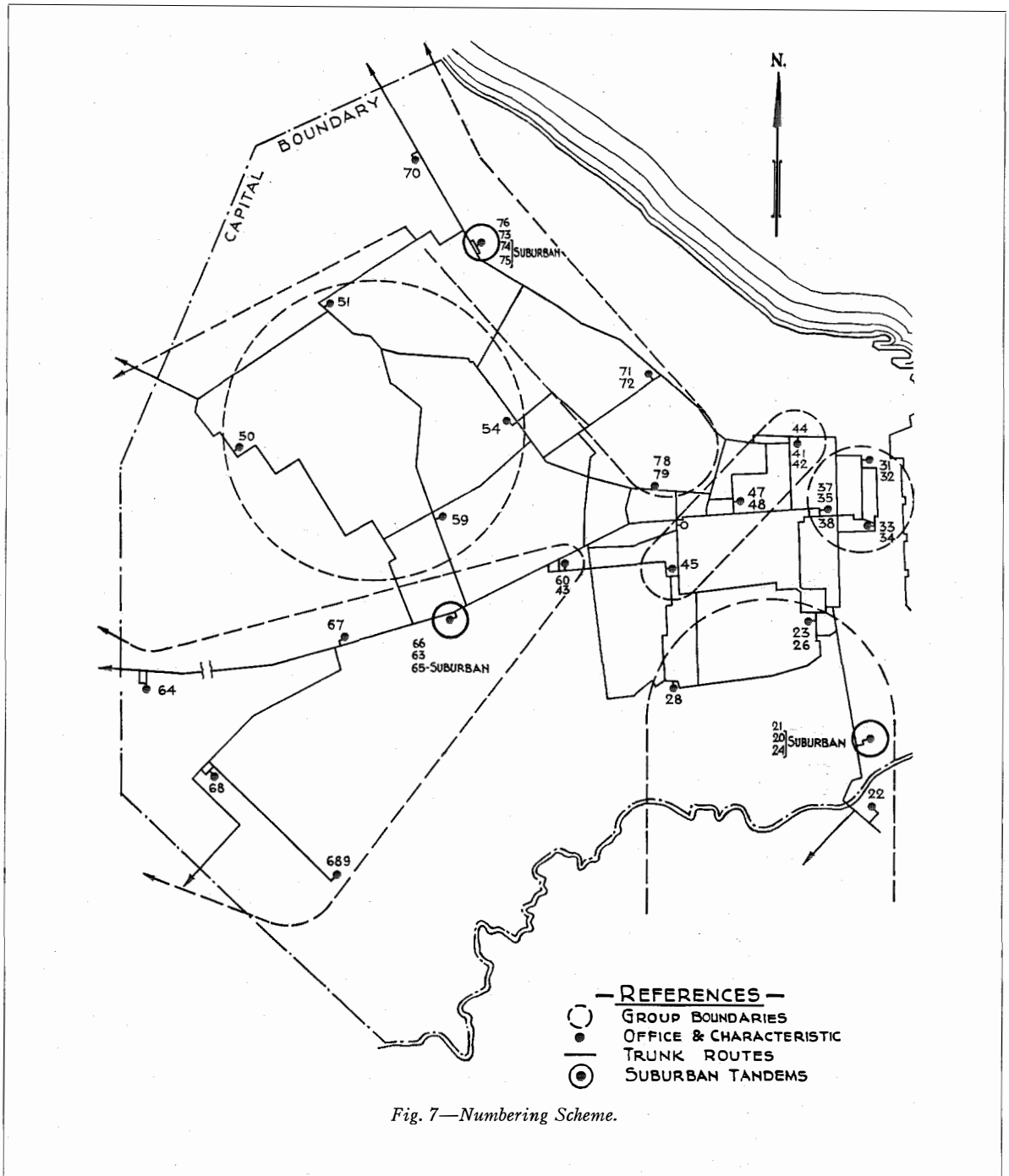

Fig. 7—Numbering Scheme.

scheme was therefore not considered. A 6-figure scheme with 2 digits in the characteristic was adopted, giving a nominal capacity of 800,000 numbers after reserving two levels for Toll and Special Services (Fig. 6). Alphabetical prefixes were not adopted, as with a two letter prefix

many names would have had to be altered, thus losing their geographical significance. The initial four offices were numbered 21, 31, 41 and 61 to provide for each office starting with a distinct digit, and also with a view to future grouping for second selector concentration. At the present

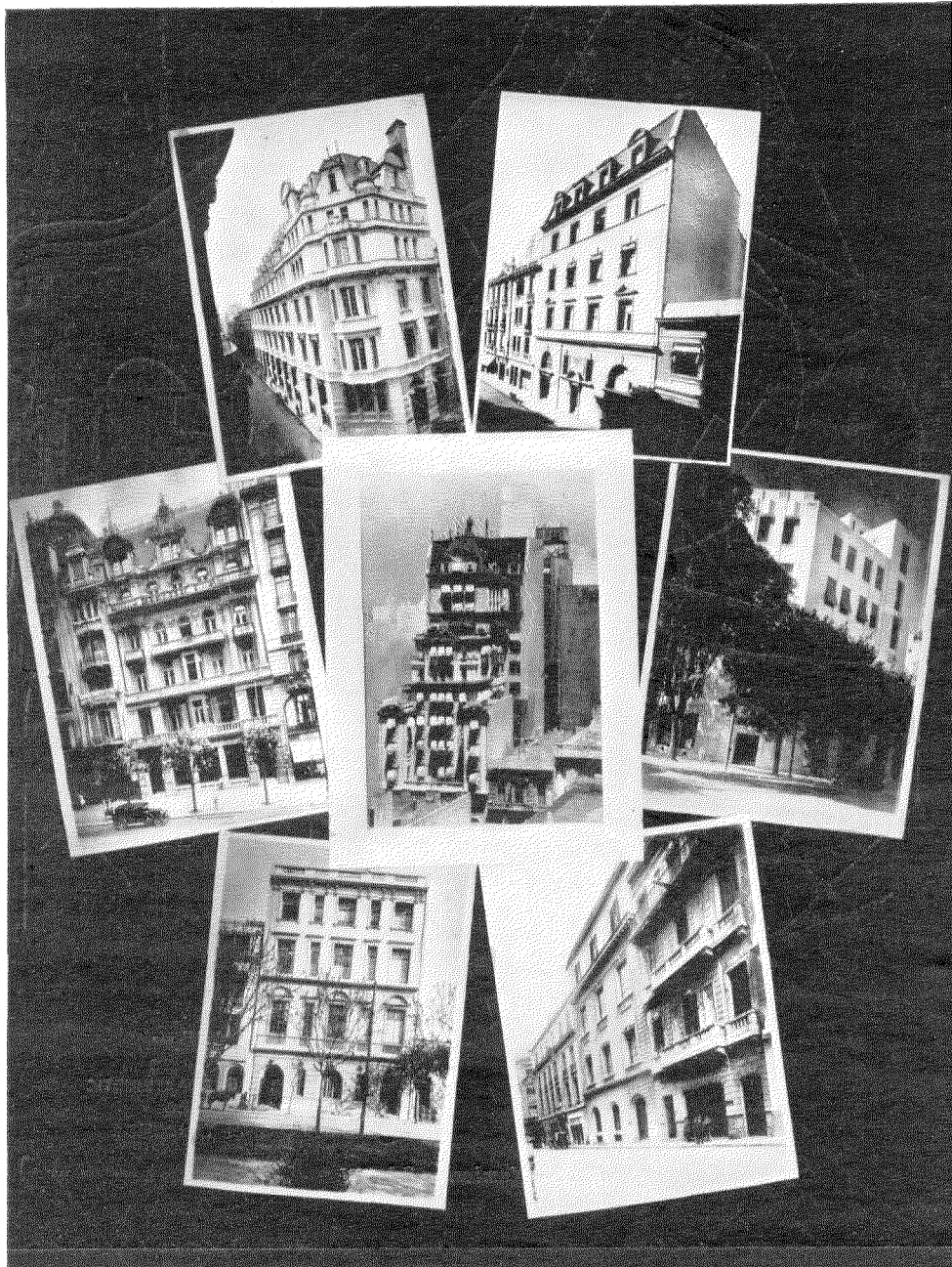

Fig. 8—Seven of the 25 Exchange Buildings of the United River Plate Telephone Company, Limited. In the center is the Administration Building which, in addition to the Executive, Commercial, Accounting and Engineering Offices, houses three Automatic Units.

day this grouping has grown to the proportion shown in Fig. 7. Due to the average length of a Capital trunk being only 3.8 miles and the trunk groups being fairly large, direct trunks are used between Capital offices. The second selectors from which interoffice trunking takes place are 200 point (20 trunk) switches, and for this reason secondary switches are not required for obtaining efficient trunk groups. It has not been found possible to prove-in second selector concentration for Capital trunks, due to the back haul and the cost of extra repeaters where units are not in the same building or close together.

Suburban Tandem

Initially suburban offices were reached by dialing two digits to the tandem operators at Flores (for the West), Belgrano (for the North), and Barracas (for the South). Later considerable economy in operating cost was obtained by placing 3rd selectors in the tandem exchange, the city subscriber dialing a 3 digit characteristic (given in Fig. 6), the 3rd digit extending the call to the local suburban operator. Suburban manual exchanges were equipped with dials to enable the suburban operator to dial direct into 1st and 2nd selectors situated at the automatic tandem points and thence to 3rd selectors in each City office.

Special Services

TOLL AND DSA

In the initial stages monitoring services (96) were attended at special DSA positions in each automatic office and long distance at Cuyo was reached by dialing 92. This involved considerable additional building costs for the extra space required by manual equipment and operators' quarters, and it was later found economical to concentrate toll and special services in four offices: one at Libertad covering the downtown zone and three at the suburban concentration centers for the North, South and West zones. Considerable economy in operating expenses resulted; the postponement of the extension of the toll building at Cuyo was also made practicable.

TIME SERVICE IN BUENOS AIRES

Time service was introduced in Buenos Aires in 1935 in collaboration with the Authorities. To

furnish it without adversely affecting the ordinary subscribers' service, arrangements were made to connect to the United River Plate Telephone Co. network a speaking clock supplied and maintained by the Naval Observatory. The City automatic exchanges, divided into three groups, are fed by three duplicate omnibus circuits. Provision has been made, in case of a fault on any part of the line, for switching in the duplicate circuit with a minimum of interruption to the service. The signal receives one stage of amplification at the Observatory and another at the automatic office, where the output is fed to special digit absorbing relay sets to which any subscriber dialing 81 has access. Level 8 was spare so that the cost of second selectors in all offices was avoided. The equipment used was designed by the U.R.P.T. Co. and constructed locally in its workshops; Cía. Standard Electric Argentina installed it.

Buildings

Of the 25 existing buildings housing automatic equipment, nine are one-story, nine two-story and seven multi-story. Records of their cost per square meter of floor space and per line of ultimate capacity indicate that the two-story buildings, as typified by Gómez (Fig. 5), are the most economical. The Administration building, which accommodates the Executive, Commercial, Engineering and Accounting offices, in addition to three automatic units, is shown in the center of Fig. 8. The new six-story extension to the Belgrano building, which houses the Northern Commercial offices, automatic equipment and the Northern Toll and DSA Concentration, appears to the right in Fig. 8.

The 25 plots in the Capital and Avellaneda cover 25,000 square meters, the covered floor space of the buildings totaling 51,000 square meters, of which 36,000 meters are for automatic equipment, equivalent to 0.1 square meters per line of ultimate capacity; the remaining 16,000 meters contain administrative offices, etc. The capacity of the present 25 buildings is 368,000 lines, equivalent to some 420,000 stations.

Due to climatic conditions, the ground floors of Buenos Aires City buildings are usually lofty; this leads to lost space with the low type equipment, but the extra space can now be advan-

tageously occupied with the new high type racks. Air cooling is not used in any office; but air conditioning is included in the specifications for all the newer buildings.

All the older buildings are steel frame and brick. Ferro-concrete has in recent years become a more economical form of construction and is now being used, Gómez being of this type.

Auto Manual Transition Equipment

In order to furnish automatic subscribers entirely mechanical service, insofar as they are concerned, prior to complete conversion, call indicator equipment was installed in the city C.B. offices. A subscriber dialing any city office number thus obtains substantially full automatic service. Automatic calls to the magneto offices Mataderos and Avellaneda were completed over jack-ended trunks on the "B" boards.

Traffic from manual offices and the suburban tandem offices to automatic was completed over keysending or dialing-in positions located in the automatic offices. In general, the traffic from all city manual offices terminated on plug-ended trunks on keysending positions unless the size of the trunk group was too small, in which case jack-ended trunks terminating on dialing-in positions were used.

As the number of automatic offices grew and the provision of further keysending equipment was out of the question, due to the short period of time it would be in use, the "A" Board cord circuits at Rivadavia, Flores and Belgrano were modified for direct dialing; the outgoing trunk multiple was fitted with visual engaged signals and the trunks connected to incoming third selectors in the automatic offices. This modification, and the gradual reduction of the number of necessary keysending positions, facilitated the elimination of a large number of keysending centers and the concentration of keysending at fewer points. In 1936 a new inward toll board was inaugurated and the positions equipped with dialing facilities, so that at the time of writing, keysending is only required for traffic from the Mitre office, the keysending points being located at Mayo and Caballito.

Power Plant Policy

Notable improvements in the type of equipment used have been incorporated in the Buenos

Aires City network during approximately the past decade. All power plant has been converted to full float operation; previously, central offices were provided with two sets of batteries, one on charge and the other supplying the office. This method meant a continuous charge and discharge of the office batteries with consequent varying voltage despite end cell switching, or C.E.M.F. cells and relatively short life of expensive batteries.

With the introduction of full float operation the life of the office battery is extended to at least 13 or 15 years of useful life, and the cost of power is reduced inasmuch as the only practical loss of efficiency is in the conversion loss in the motor-generator. Further, manual attendance at the power board is reduced to a minimum, and a smaller battery is required, giving a five-hour busy hour reserve.

To provide for serious failures, two portable Diesel electric units, mounted on trailers, have been provided, either of which is sufficient to supply a complete exchange with power at very short notice. One of these units is capable of furnishing 380/225V, 50 cycle, 3 phase, so that in the event of a failure the office can be supplied with power and lighting. The other unit is equipped with a 24/60 volt d.c. telephone type generator for use in offices where the main supply is d.c., or to supplement the other unit where a multi-unit office is involved. In the long distance office, which also houses two units of automatic equipment, a permanent Diesel 112 HP unit driving a 100 K.V.A. alternator has been installed. This will meet all requirements for power in such an important office, should the necessity arise.

All new offices to be built will be provided with a Diesel electric set for emergency purposes. The size of the office battery can therefore be reduced still further, thereby justifying on a cost basis alone the provision of emergency equipment.

Modifications and Improvements in Equipment

The automatic equipment installed throughout the Capital is of the step-by-step two-motion switch type. The earlier installations used the 25-point rotary line switch for each subscriber,

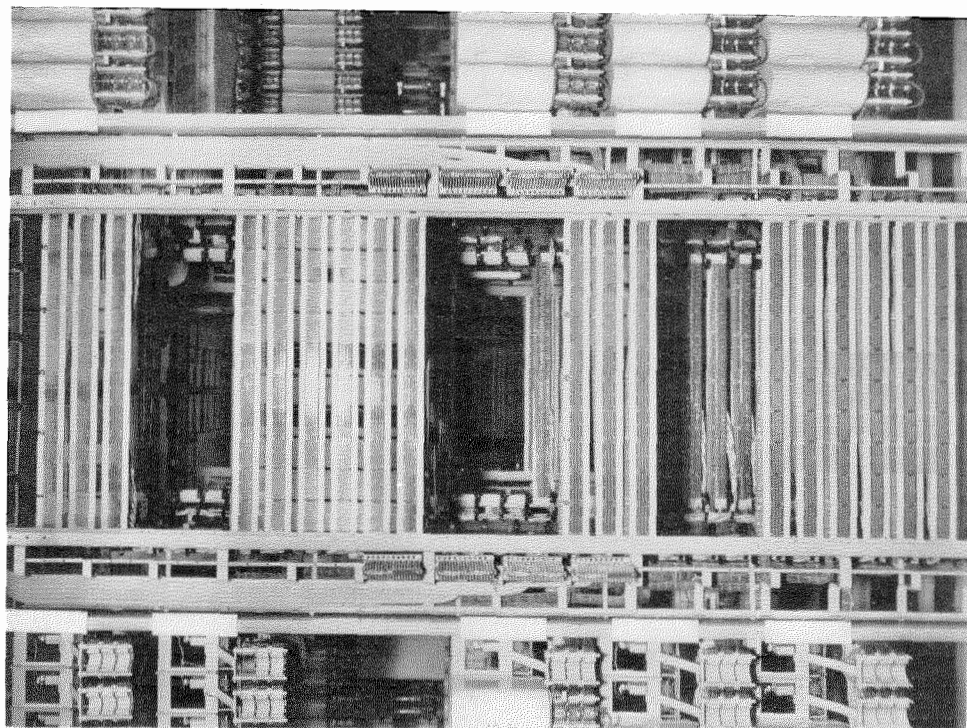

Fig. 9—Automatic Equipment Rack Utilizing Piano Wire Type Assembly.

mounted on line switch units common to this class of step-by-step equipment. From about 1931, the rotary line switch was replaced by the step-by-step two-motion line finder. This change resulted in certain floor space saving and suppressed one additional type of mechanism requiring maintenance, leaving the newer offices with only one class of mechanism. From the outset the 10-level 20-trunk two-motion selector was adopted for reasons discussed under the section on Numbering Scheme. The only exception to its use throughout the network is the Juncal office, which is a 10-group 10-level selector. In this office, however, all the large inter-office trunk groups are routed via secondary line switches of the Keith type with corresponding increased efficiency on these trunk groups.

The offices as originally installed had their selector equipment mounted on the double-sided trunk board usual in step-by-step practice. Commencing about 1931, 11'6" single-sided type

racks were adopted, the design of these racks being practically identical with Bell System practice. The adoption of this high type rack, on which all classes of equipment, including line finders, connectors, group selectors and outgoing relay sets are mounted, has reduced the floor space requirements by some 25 percent.

Owing to building heights, two groupings of the single-sided racks were developed, one 11'6" in overall height, the other 8'6".

In order to cater for the 10-level 20-trunk switch, the corresponding terminal assembly had to be especially designed. The original layout of this assembly involved a build-up following the shelf and level segregation principle, in that each level was a complete build-up allowing grading facilities, splitting of shelves, etc., to be done by commoning on pinch type terminals, such build-up being repeated for each of the 10 levels. The later equipment, however, utilizes the piano wire type assembly, illustrated in Fig. 9, and has

proved much more flexible from a working point of view than the previous one. This factor is of great importance in this area, owing to the amount of installation movement which takes place.

The line switch unit offices carry an individual I.D.F. mounted upon each unit with cross-connecting facilities between all units. On the adoption of the line finder the standard line I.D.F. was introduced, but in the later offices this has been omitted, the equipment being tightly cabled between M.D.F. line finder rack and final selector rack.

From the foregoing it will be seen that a large number of the older offices contain a very mixed class of equipment, and not the least of the problems has been to combine in an efficient manner these various types of equipment and racks. During one period offices were installed with racks carrying 400 line switches each. Only a few offices, however, contain this equipment which was developed just prior to the adoption of line finder working. The latter principle was adopted since it gave considerable economy over the line switch arrangement, especially in the lower calling rate offices. Line finder working is also used to take care of dead number and out-of-order traffic, such traffic being terminated on the banks of line finders which connect to the special service positions.

Discriminator Offices

A form of satellite working has been adopted for outlying offices and avoids the use of two trunks during a local conversation. This "bypass" equipment consists of a normal line finder which is searched for over the arcs of a rotary line switch by a discriminator—a two-motion switch which operates in parallel with a distant incoming selector at the main office which received the two first digits dialed. Should the call be other than local, the discriminator releases, leaving the circuit through to the main office and the discriminator available for the next call. In the case of a local call, the discriminator releases the outgoing junction and trunks the circuit through to local selectors, freeing the equipment in the main office. This equipment has proved successful in operation at Nueva Chicago and it is planned to extend its use to future suburban offices where it is justified by the percentage of

local traffic and other factors. The Nueva Chicago office serves a large industrial area to the southwest of the city; all trunks, for geographical reasons, have to be routed via the Flores office. It was therefore decided to use by-pass equipment with discriminators for this office and route all traffic via the Western Zone automatic tandem located in the Flores-Volta building. This reduced the number of trunks required in the section Nueva Chicago-Flores since they are combined in one group. From Flores inwards to the Capital exchanges, a large saving in trunks is also obtained by the combination of the Nueva Chicago trunks with the West automatic concentration trunks to each City office.

3-Wire Working

In all cases where more than one unit is located in the same building, as for example Rivadavia-Mayo-Libertad, inter-working between each unit is 3-wire. This method is being extended to adjacent offices where economical, a relay being used in the private wire when necessary.

Protection

The initial installation carried full main frame protective devices; that is, heat coils, arresters and fuses. As the area is almost entirely on an underground basis, it was decided to suppress all main frame fuses. Heat coil and arrester protection on interoffice pairs had been eliminated previously, all such cables being terminated on protector strips with dummy carbons and heat coils to facilitate the use of a test shoe. The present practice is to terminate these underground cables on terminal blocks. In the earlier installations of two offices located in the same building the first and second selectors were common to the two units. It was found, however, that the small economy secured was offset by the additional installation movement and terminal assembly changes required for extensions.

The present policy is to tend to separate the two units completely except from a power plant and main frame viewpoint, or where external trunk groups are small.

Tones

Dial tone was not incorporated in the initial equipment since the use of line switches and the

generous provision of first selectors made it inadvisable. With the increase in calling rate and the use of line finders, it was found that the introduction of dial tone would be advantageous and this was inaugurated in 1938 with benefits to both the public and the Telephone Company, the first selectors being reduced in number to give a grade of service of 1 in 100, instead of 1 in 1000, without incurring any noticeable delay. An interrupted busy tone was previously used corresponding to the Spanish word "ocupado." This is now being replaced by a standard 400 cycle busy tone, interrupted twice per second.

Force Adjustment

Two factors of the utmost importance in planning the conversion were even distribution of load on the factory and adjustment of the operating force. Virtually no operators have been laid off during the conversion, the excess personnel having been absorbed by a growth of 24,000 manual lines in the suburbs of Buenos Aires, and by the normal resignations, which average some twenty per month.

Installation

It will be seen from the curve shown in Fig. 3 that the average amount of equipment installed in Buenos Aires has been approximately 15,000 lines per year. This average has been more or less constant except during the 1931/35 crisis years, thus allowing an almost fixed force on installation work to be maintained. The installation of an equal number of lines each year does not cater necessarily for the actual subscribers' relief requirements, and it has been almost a normal procedure to put into service partial relief on large installations, and in some cases inaugurate offices with only a portion of the actual installation completed. Experience shows that the disadvantages of such relief are more than offset by the advantage of maintaining a constant skilled personnel.

Due to the distance at which the installation force was operating from the factory, the close contact which is normal between the Engineering and Installation Departments was difficult to maintain, the installation movement in the offices being of such magnitude that the cable rack and cable engineering had to be carried out on

site in some cases. To handle this installation work, an average of one hundred men have been employed in the Capital. This covers the installation of the automatic offices proper, associated trunking equipment throughout the network for the introduction of new offices, general trunking rearrangements due to variations in traffic, and transition equipment for working between automatic and manual. The inauguration of partial reliefs did not allow offices to be routined prior to inauguration over the length of time which is usual in step-by-step installations. It was therefore decided, in order to ensure the correct functioning of the equipment, to readjust all switches completely prior to placing them in service. Considerable time was thus gained since rearrangements could be effected whilst the actual erection was proceeding.

The main advantage of centralized handling of switch adjustment lies in the fact that the work can be done on a mass production basis and semi-expert staff employed to a greater extent than would be the case if the switches were adjusted on site in the individual offices. Centralization also permits closer control of the quality of the equipment and a strict check on the time involved.

During the whole of this transition period, the Argentine supervisory staff has been constantly increased, and the installation force includes many Argentineans. Practically the whole of the equipment installed is of British manufacture, the exception being the Juncal Office which was supplied from the U.S.A. The majority of the British manufactured equipment has been supplied by Standard Telephones & Cables, Ltd., London.

It is interesting to note that even with the long shipment involved, the amount of equipment damaged or lost since September, 1939, has been practically negligible.

Conclusion

The automatic system of Buenos Aires at the date of 100 percent conversion (1942) will consist of 40 offices in 25 buildings with 267,000 lines of equipment installed as follows:—

Offices	Effective line capacity of equip.	Ultimate line capacity of present buildings
40	256,000	368,000

The Buenos Aires automatic area, covering 238 square km, has increased in population, during the years of conversion from manual service, from 1,160,000 inhabitants to 2,860,000. In the same period, the number of telephone stations has increased from 62,000 to 270,000. Thus it

will be seen that, in the process of conversion, not only were facilities provided to meet existing demands on the basis of telephone usage at the time the plans were drawn up, but also to take care of an increase from 3.9 percent to 9.5 percent in the station-population ratio.

A New 30 Kw Short Wave Radio Transmitting Equipment for South America

By F. D. WEBSTER and R. E. DOWNING

Federal Telegraph Co., Newark, N. J.

I. Introduction

VERSATILITY, flexibility and dependability, attained by the application of many recent significant developments in the art, characterize the 30 kw short wave radio transmitting equipment described in this article.

Versatility is attained by making the equipment capable of operation:

- (a) On any frequency between 5.7 mc and 22 mc;
- (b) With crystal control or with self excitation;
- (c) For CW or MCW telegraphy or by means of a separate modulator for telephone or broadcast;
- (d) To deliver 1 kw or 30 kw of radio frequency power on telegraphy or 9 kw on telephony or broadcast;
- (e) Into a balanced transmission line of 600 ohms surge impedance with any standing wave ratio up to two to one.

Flexibility is achieved by construction of the equipment in four mechanically separate units and by the provision of controls which permit rapid and convenient transfer to any type of operation. The four units comprise an R.F. driver, a power amplifier, a 3000-volt rectifier and a 10,000-volt rectifier. For telephone operation two more units are required, namely, a speech amplifier and a modulator. It is planned to add these two units at a later date; consequently, the present description covers only the radio frequency equipment and its associated power equipment.

Dependability is insured by the design of each component so that it will reliably meet the electrical and mechanical operating field conditions. Protective features include special provisions for safeguarding both personnel and equipment.

Voltage breakdown, which is an ever-present hazard due to the high voltages produced in radio

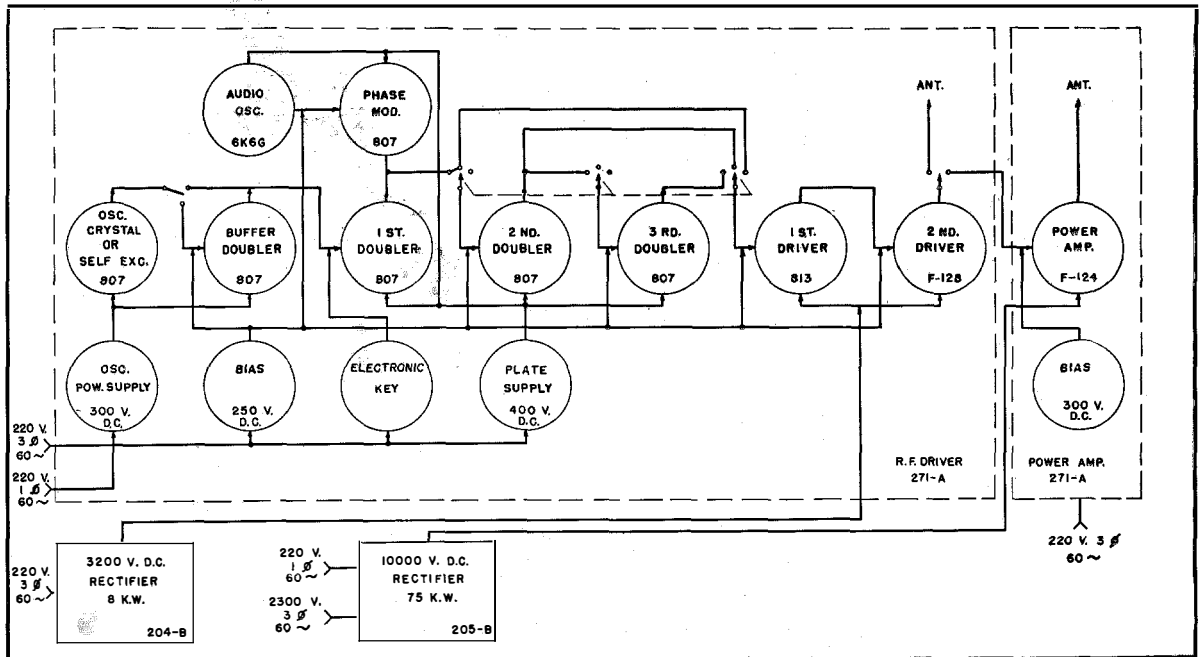

Fig. 1—Functional Schematic of 30 kw Radio Transmitter.

equipment of this power, is minimized by adequately spacing and insulating all components, by avoiding sharp edges on metal parts, and by installing corona shields and horn gaps where applicable. Excessive temperatures are avoided by employing such means as adequate current-carrying capacity in all conductors, ample radiating surfaces, water cooling, and forced air circulation by means of blowers.

Recent developments incorporated in this equipment include:

- (a) Electronic keying with weight control;
- (b) MCW telegraphy by phase modulation;
- (c) Special type balancing network;
- (d) Multi-strand filament tube;
- (e) Vacuum condensers.

II. Electrical Design

1. GENERAL

The functional electrical design of the complete equipment is illustrated schematically in Fig. 1; it shows the tube line-up and the function of each stage. The R.F. driver unit (Fig. 2) supplies radio frequency power: continuously for telephony or, when keyed with or without tone modulation, for telegraphy. It requires an external 3000-volt d-c plate power supply in addition to the power supplies included in the unit. This requirement is met by the 3000-volt three-phase mercury vapor rectifier (Fig. 3). These two units supply excitation to the power amplifier or, when used alone, form a complete 1 kw radio transmitter. The power amplifier (Fig. 4) amplifies the driver output to 30 kw for telegraph operation and is capable of modulation for telephony or broadcast to deliver 9 kw output. It requires an external source of d-c plate power which is provided by the 10,000-volt mercury vapor rectifier (Fig. 5).

2. CONTROLS

Each unit of the transmitter is equipped with controls for starting and stopping that unit. The keying circuit permits the transmitter to be keyed from the power amplifier, from the driver or remotely. It may be locked in the key-down position by means of a switch on the driver unit. The 3000-volt plate voltage can be applied to the driver by push-button stations on the power

amplifier or on the 3000-volt rectifier. A plate supply control on the power amplifier prevents that unit from being connected simultaneously to more than one 10,000-volt rectifier.

3. PERSONNEL PROTECTION

The problem of personnel protection associated with high voltage equipment has been given considerable attention. The following precautions have been taken in the various units:

(a) 10,000-Volt Rectifier

The 10,000-volt rectifier is completely enclosed with no exposed high voltage components. Parts

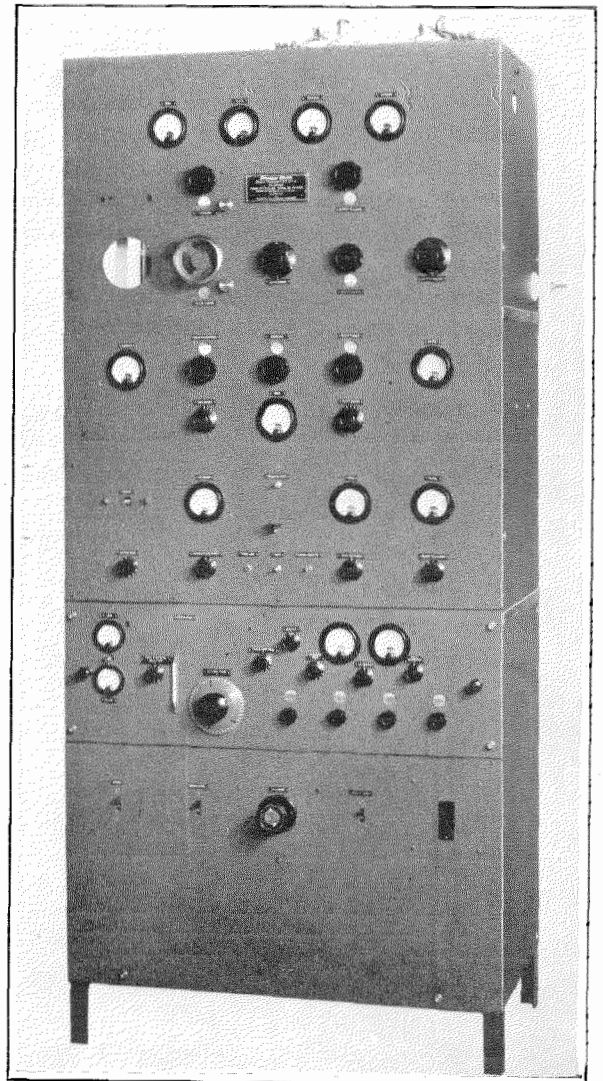

Fig. 2—Front View of R.F. Driver Unit.

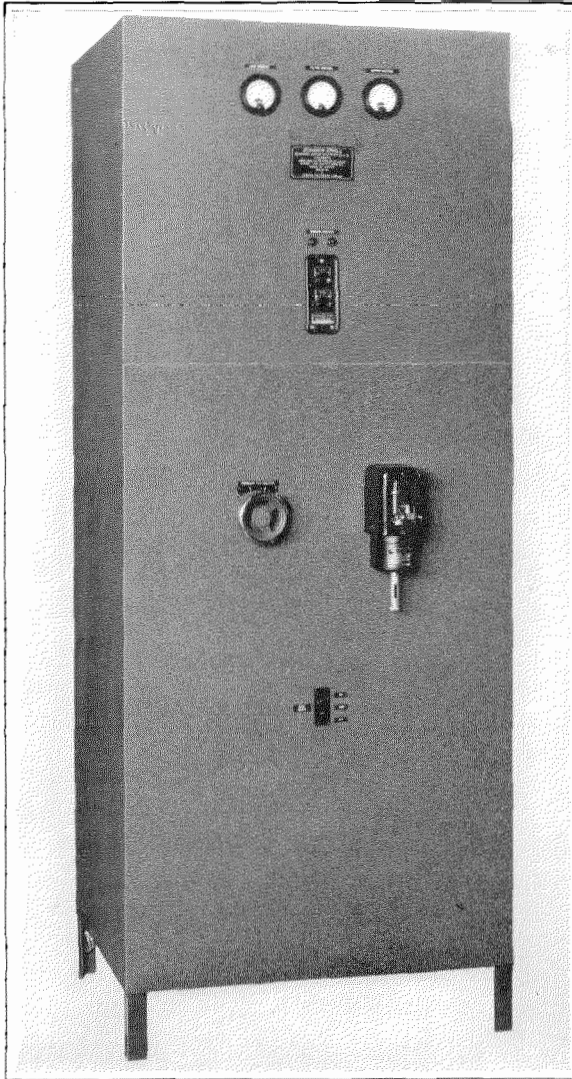

Fig. 3—Front View of 3000-Volt Rectifier.

such as high voltage plate transformer terminals, which might be reached by small objects through the screening, are protected by fixed baffles. Both access doors have electrical interlocks which open the main circuit breaker upon opening the door. In addition, the doors are fitted with mechanical grounding devices which short the high voltage system to ground when the doors are open. An additional manually operated grounding switch is supplied on the front panel which opens the main circuit breaker and grounds the high voltage. The 2300-volt three-phase incoming power lines terminate in an additional enclosure

within the main enclosure and are arranged to be inaccessible.

(b) *3000-Volt Rectifier*

An electrical door interlock of the "pull-apart" variety and a grounding contactor perform the functions of removing the supply voltage and grounding the 3000-volt d-c output upon opening the access doors.

(c) *Driver Unit*

Protective devices similar to those on the 3000-volt rectifier cut the supply to that rectifier and ground the 3000 volts in the driver unit when opening the access doors.

(d) *Power Amplifier*

Dual door interlocks are provided on each access door of the power amplifier unit. In order to turn the door latch, it is first necessary to push a button which operates a high voltage oil switch

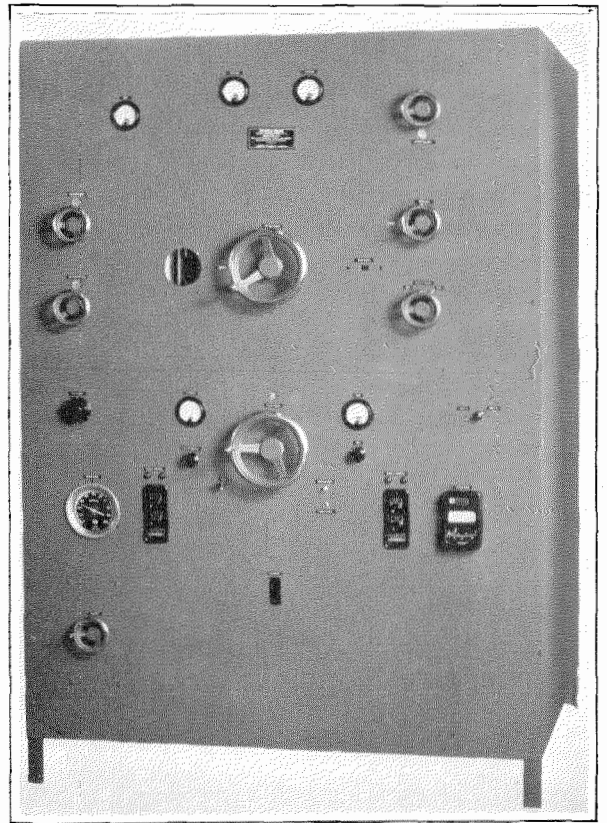

Fig. 4—Front View of Power Amplifier Unit.

located in the main rectifier to remove the voltage from the 10,000 volt line feeding the power amplifier in question. Opening the door causes the pull-apart interlock switch to remove the bias and to operate a contactor to ground the high voltage supply bus within the power amplifier. This arrangement of opening the d-c line to the power amplifier is used rather than opening the main oil circuit breaker of the rectifier because the rectifier may be used to supply two power amplifiers simultaneously. The scheme permits de-energization of one power amplifier without affecting the operation of the other while at the same time providing good personnel protection.

4. R.F. DRIVER UNIT

(a) General

The R.F. driver unit includes in one metal cabinet, the oscillator, buffer-doubler, three doubler and two driver stages together with the phase modulator and all power supplies except the plate supply for the two driver stages. The oscillator covers a frequency range of 980 to 1460 kilocycles when self-excited and 1960 to 2920 kilocycles when crystal controlled. Selection of any one of six crystals or self-excited operation on any one of four frequency ranges is provided by a single switch. The buffer-doubler stage operates as a frequency doubler and isolates the oscillator from the first doubler stage which is keyed and modulated. It is used only for self-excited operation and is disconnected for crystal operation by means of a switch. Another switch is provided whereby one, two or three doubler stages may be connected in the circuit, the number of stages chosen depending upon the desired output frequency. The output of the doubler stages is applied to the first driver stage which employs a beam type power amplifier tube. This in turn excites the final driver stage. The output of the final stage may be supplied to the power amplifier or, through an Alford network (a special type balancing network), to an antenna.

(b) Frequency Control (See Fig. 6)

The oscillator is installed in a constant temperature oven. The oscillator and the thermostatically controlled oven heater each have an

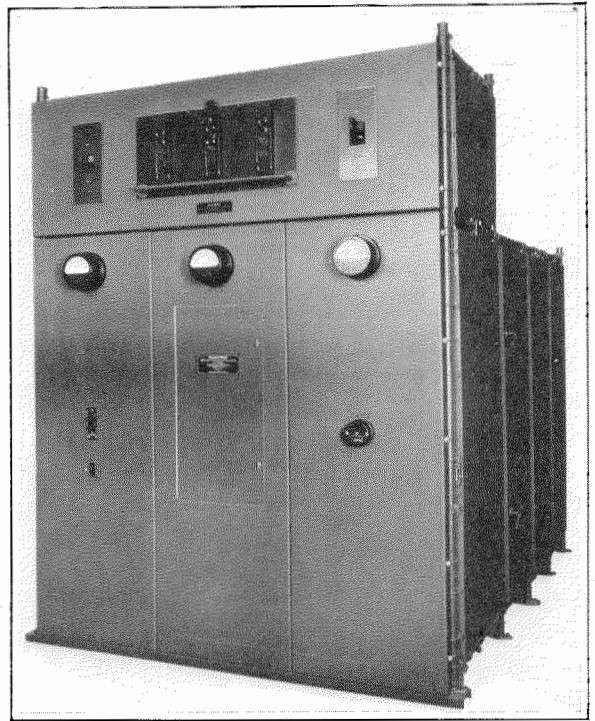

Fig. 5—Front View of 10,000-Volt Rectifier.

individual power switch; both switches are connected to the power mains by a circuit which is independent of the rest of the equipment. The arrangement permits either the oven or the oscillator or both to be continuously energized or to be energized sufficiently in advance of the operation of the rest of the equipment to allow the temperature to stabilize. The oscillator filament and plate voltages are maintained constant within 1 percent independently of line voltage fluctuations between 170 and 250 volts. This is accomplished by an automatic voltage regulator which employs the properties of a magnetically saturated iron core and a partially resonated circuit. In this way, the principal causes of oscillator frequency deviations are eliminated.

(c) Oscillator Temperature Control

Whereas a high degree of temperature control would not be required with the low temperature coefficient crystals employed, a rather close control of temperature of the electric oscillator components is considered desirable. Therefore, a device has been included with the oscillator oven

which may be adjusted to compensate for heat leakage which may take place despite the dual insulation used about the oven. It consists of a heat conducting vane with a part of its surface outside the oven and thus exposed to ambient temperature. The portion of the vane inside the oven is in close proximity to the thermostat. The whole assembly is arranged to be adjustable so that more or less heat, as desired, may be transferred from the vicinity of the thermostat to the outside, thus permitting maintenance of the temperature inside the oven within close limits. The inner oven is lined with heavy metal to provide great heat inertia so that fluctuations in temperature of the outer oven, where the heaters and thermostat are located, will not be transferred to the inner oven, or at least will be greatly retarded. Thus, if falling ambient temperature depresses the inner oven temperature, the vane is moved nearer to the thermostat to withdraw heat faster from the thermostat; this causes the latter to be closed a greater proportion of the time, thereby raising the average temperature of the outer oven and maintaining the desired temperature of the inner oven.

The temperature of the inner oven thus is held within close limits without requiring a thermostat so sensitive as to need an auxiliary relay system to handle the heater circuits.

(d) *Keying*

On-off keying of the transmitter is employed for both CW and MCW telegraph operation; it is accomplished by applying to the control grid of the first doubler stage, when the key is open, fixed bias sufficient to block the tube. When the key is closed the bias is reduced to the normal operating value. The key controls the grid bias of the doubler stage through an electronic keying circuit which includes a weight control. The weight control allows the relative duration of marking and spacing pulses for dots to be adjusted. A filter is inserted between the electronic keyer and the doubler grid circuit to shape the telegraph characters and minimize key clicks. A monitor consisting of a diode rectifier electrostatically coupled to the R.F. output is provided so that, by connecting an oscilloscope to its output, the shape of the telegraph characters can

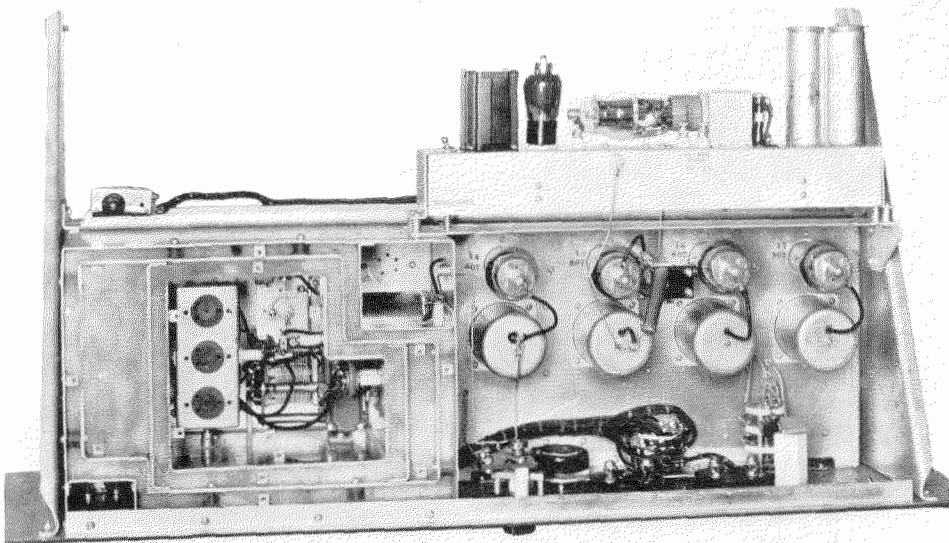

Fig. 6—Top View of Oscillator-Multiplier Tray.

be observed. The keying circuit allows the transmitter to be keyed at any speed up to 400 words per minute.

(e) *Phase Modulation (See Fig. 6)*

Tone modulation for MCW telegraphy is obtained by phase modulation which is indistinguishable from frequency modulation when a single constant modulating frequency is used. It has the advantage over the latter of not affecting the carrier frequency and thus eliminates the necessity for special frequency control circuits. This type of modulation was adopted in preference to amplitude modulation because it produces a distinctive signal that is more easily read through interference and, in addition, it generates multiple sidebands which contribute to reduction of selective fading. Further, it accomplishes these results with a minimum of equipment and power consumption.

(f) *Lange Neutralizing Circuit (See Fig. 7)*

The R.F. driver unit output stage employs an air-cooled triode (Type F-128-A) operating as a neutralized power amplifier. It embodies the Lange neutralizing circuit which accomplishes neutralization by a principle entirely different from other commonly used circuits; with the tube grid-plate capacitance, it forms an unsymmetrical bridged T network. The series element connected to the grid is a tapped inductance, the series element connected to the plate is a fixed condenser and the shunt element which connects to ground is a variable condenser. One of the advantages of this circuit is that any two elements may have any desired value. When these two values have been chosen, the value of the third element is fixed by the relation for neutralization. The arrangement used in this equipment has been found highly convenient. In this case, the plate neutralizing condenser is fixed and has a capacity approximately equal to the tube grid-plate capacity. The grid neutralizing condenser is variable with an average capacity about four times that of the plate neutralizing condenser. The inductance is tapped at such intervals as to permit neutralization within the range of the variable condenser over the complete range of frequencies. Neutralization is obtained by adjustment of the variable condenser.

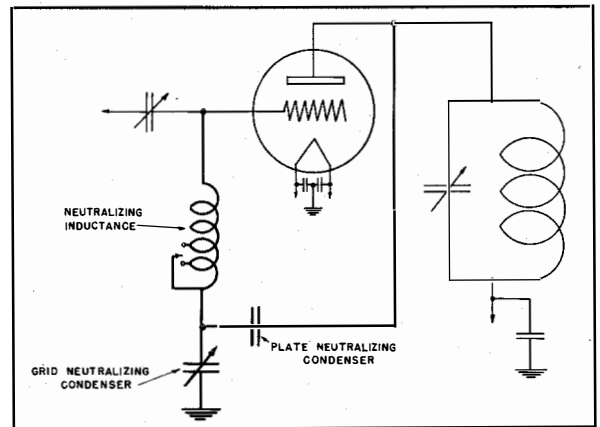

Fig. 7—Lange Neutralizing Circuit.

(g) *Output Circuit (See Fig. 8)*

The output circuit of the R.F. driver unit consists of two tuned circuits inductively coupled. Five adjustments are provided, thereby allowing the most effective condition to be obtained for any load or frequency. This type of output circuit also effectively reduces harmonics.

A switch is provided in order that the R.F. driver output may be connected either to the power amplifier or to an antenna through a balanced transmission line. Although the output stage uses a single ended circuit, a balanced output is provided suitable for feeding a two-wire transmission line by employing a special type balancing network. The latter consists of two identical tapped inductances and a variable condenser connected in star. The condenser leg connects to ground and the two inductance legs connect to the two sides of the transmission line. One transmission line conductor connects to the high potential side of the driver output stage. The network is balanced for only one frequency so that for each frequency the proper tap on the inductances must be selected and the variable condenser adjusted until no parallel currents flow into the output circuit, a condition which is approximately achieved when the two R.F. meters in the transmission line indicate equal currents.

(h) *Antenna Meters*

The antenna is fed from the transmitter through a two-wire transmission line for which two terminals are included in the driver unit.

These terminals are connected to the output of the special type balancing network by heavy conductors. Electromagnetically coupled to each of these conductors by means of a small shielded and grounded loop of wire is a thermocouple. The thermocouples supply the two R.F. ammeters located on the front panel of the R.F. driver unit. The coupling between the conductor and the loop is adjustable and is set to give a correct indication of transmission line current at that point. This arrangement prevents the antenna meters from being damaged by lightning.

5. POWER AMPLIFIER UNIT

(a) *Vacuum Tube with Multi-strand Filament*

The power amplifier unit employs a water-cooled triode with a six-strand filament (Type F-124-A) in a neutralized amplifier circuit. The tube requires a total filament power of 5.6 kw at 27.2 volts, representing 206 amperes in a single-strand filament and 68.7 amperes per strand in a six-strand filament connected three-phase. The six-strand filament thus permits the use of conductors and terminals in the filament circuit of a more convenient size. An additional advantage is that the filament may be supplied from a three-phase source resulting in a reduction in hum modulation from the filament. Filament starting current surges are limited by high reactance filament transformers. The rated filament voltage is obtained for various line voltages by a three-phase continuously adjustable auto-transformer.

(b) *Filament By-Pass Condenser (See Fig. 9)*

Parasitic oscillations are frequently present on

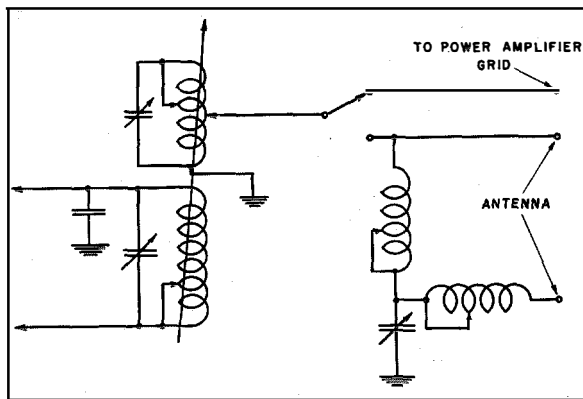

Fig. 8—Driver Output Circuit.

the filament leads of high power tubes if the filament is not by-passed to ground for radio frequencies at the filament terminals. For this reason, each filament strand is by-passed to ground at the tube terminals by an assembly of mica condensers of original design. The connection to each tube filament terminal is made by a clamp with a large hexagonal head screw. Each clamp is attached to a circular plate provided with holes to pass the clamps for the other terminals. The six plates are stacked vertically with a grounded plate at each end and between each of the other plates. All the plates are separated by sheets of mica. The grounded plates are connected to the tube cap by a clip and to ground by a short heavy strap. The terminal clamps are located so that the assembly fits over the tube terminals and is supported on them. The filament supply leads are flexible stranded conductors and are attached to the same condenser plates as the corresponding clamps but to the opposite surface by means of special terminals. This condenser unit is compact and convenient to attach to the tube. The use of hexagonal head screws on the clamps renders practicable the removal of the assembly when it is at operating temperature by loosening the screws with a wrench.

(c) *Vacuum Condenser*

This stage employs the Lange neutralizing circuit previously described. The fixed condenser in the branch to the plate comprises four vacuum condensers in a series parallel connection, giving a capacity approximately equal to the tube grid-plate capacity. At the high voltages involved in this unit (18,000 volts), the vacuum condensers represent a large saving in space over an equivalent fixed air condenser.

(d) *Bias Supply*

Included in the power amplifier unit is a 450-volt fixed bias supply which biases the tube to cut-off when the R.F. drive is removed. Under normal operation, the tube employs grid leak bias and the fixed bias is made ineffective for all grid leak bias voltages larger than that of the fixed bias by connecting the fixed bias supply in parallel with the grid leak bias through a pair of high vacuum rectifier tubes. These two rectifier

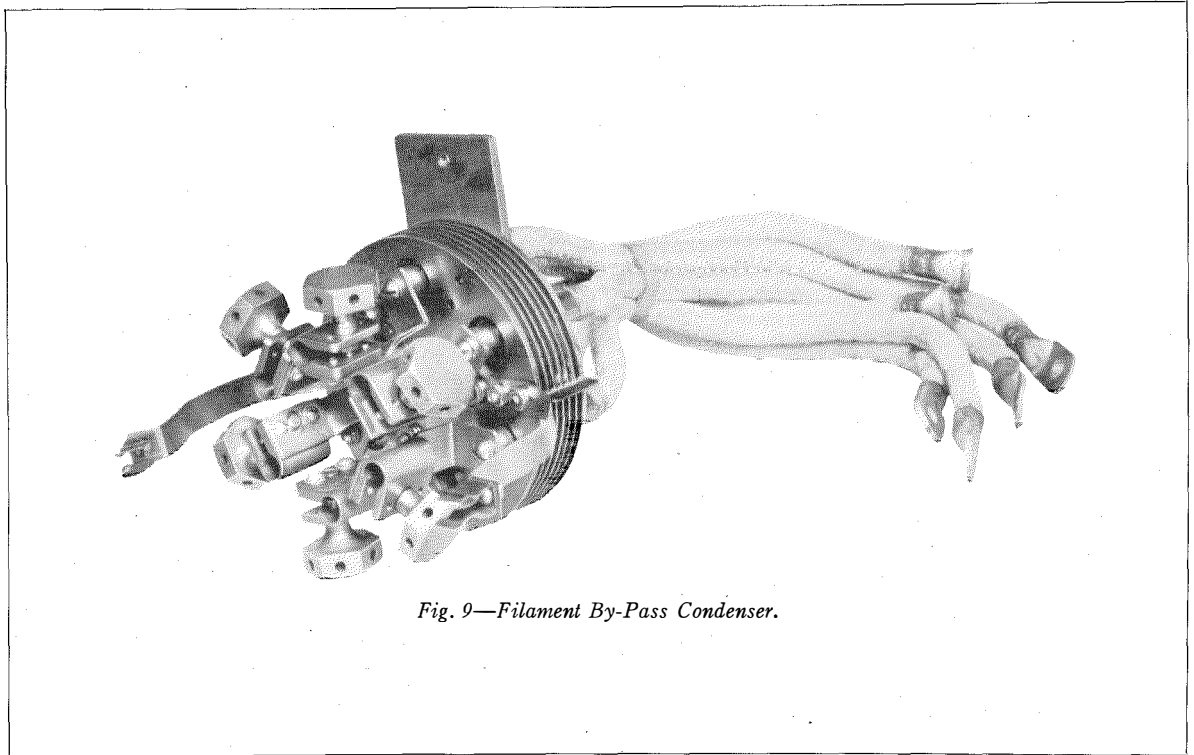

Fig. 9—Filament By-Pass Condenser.

tubes are connected in parallel and prevent the grid current from flowing in the fixed bias supply. The amount of grid leak bias must be greater for telephone operation than for telegraph. The grid leak resistor has the proper value for telephone operation but with a section short circuited by the normally closed contact of a relay to give the correct resistance for telegraphy. For telephone operation, the relay is energized and removes the short circuit.

(e) *Water Cooling System*

The power amplifier water cooling system is designed for connection to the water mains and requires 16 gallons per minute at 45 pounds per square inch pressure. The water system cools both the tube and the plate tank inductance. Loss of radio frequency power in the water system is minimized by the use of porcelain water coils. A contact-making flow meter is included which causes the unit to be shut down whenever the water flow drops below a safe amount. It is also arranged so that if the filament power is applied before the water is turned on a warning

signal is given. Further, an outflowing water temperature indicator is provided which causes the power to be removed if the water temperature becomes excessive. A part of the circulating water is caused to flow through the copper tubing of the main plate tank inductance to provide cooling for the coil.

(f) *Plate and Output Circuits (See Fig. 10)*

The plate tank inductance is a "rams horn" type coil; that is, it consists of two equal sections connected in parallel and wound in opposite directions along a common axis so that their fields reinforce each other. Water is supplied to this coil through a porcelain insulating water coil and enters the tank coil at each end of the "rams horn," exhausting at the center into the side of the tube water jacket. Power is taken from the plate circuit by a coupling coil, which is likewise in two sections connected in parallel and wound so that the two sections are aiding. A section is located at each end of the plate inductance. This type of coil construction provides increased mutual inductance which is especially advan-

tageous at the higher frequencies where only a small portion of the total inductance is in use. The output coupling coil is tuned by a variable condenser which may be connected either in series or parallel; selection is made by a special switch fitted with an interlock which removes the plate voltage before a change can be made. This feature adds to the convenience of adjusting the transmitter and facilitates obtaining the optimum adjustment under various operating conditions.

Changes in tuning ranges are effected by short circuiting the proper number of turns of each coil, shorting bars of various lengths being supplied for this purpose. These bars are fastened to the coil by screws with large hexagonal heads for which a special wrench is provided so that the frequency can be changed even when the coils are at operating temperature.

Air condensers have proved more satisfactory than mica condensers for plate by-pass in high frequency and high power transmitters. For this reason, the plate by-pass condenser is a three-plate fixed air condenser incorporating a frame partition as one plate.

The plate tank tuning condenser and the output coupling condenser are both individually shielded. The shielding not only makes the circuits less critical to adjust at the higher frequencies but equalizes the voltages on the condensers thereby minimizing possible flashovers due to misadjustments or standing waves on the condenser frames.

The output coupling circuit connects to a special type balancing network which, except in size, is identical with the one in the R.F. driver unit. The use of two tuned and inductively coupled circuits reduces harmonic radiation.

6. 3000-VOLT RECTIFIER UNIT

The 3000-volt rectifier unit is rated at 8 kw and supplies d-c voltages of 3300, 3000, 2800 and 2200 volts. The rating of this unit is much larger than the power requirement of an R.F. driver unit so that capacity is available for supplying two driver units and two modulators simultaneously if desired. It is energized from the 220-volt, 60 cycle, three-phase mains. Six type F-353-A mercury vapor tubes in a three-phase full-wave rectifier circuit are utilized.

Any one of the above mentioned d-c voltages

is obtained by turning a handwheel located on the front panel. This handwheel actuates tap switches on the three-phase plate transformer; they connect to taps on the primary windings. It also actuates an interlock switch to open the primary oil circuit breaker and to remove voltage from the transformer before the taps are changed. Voltages of one-half the normal voltages can be obtained by operating the unit as a half-wave three-phase rectifier. A terminal is provided for this purpose, connecting to the neutral point of the wye-connected plate transformer secondaries. One-half voltage operation will be used only when the R.F. driver is modulated for telephony or broadcast.

Filament voltages are held constant under line voltage fluctuations by an automatic voltage regulator of the saturated core type.

Tube temperatures are maintained within proper operating limits by a blower operating into a duct which distributes the cooling air to each tube.

7. 10,000-VOLT RECTIFIER UNIT

The 10,000-volt rectifier is a self-contained unit rated at 75 kw and is adequate for supplying a power amplifier and modulator or two power

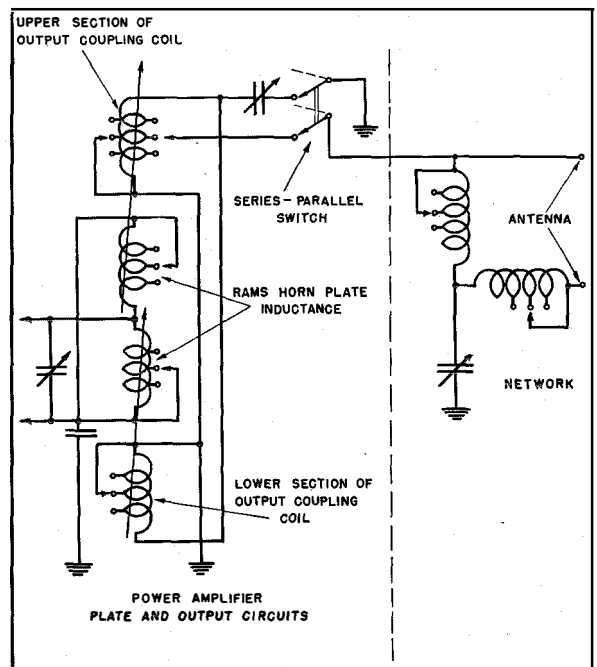

Fig. 10—Power Amplifier Plate and Output Circuits.

amplifiers. It employs six type F-369-A mercury vapor tubes in a three-phase full-wave rectifier circuit. By replacing these tubes with type F-357-A tubes its rating can be increased to 110 kw. The d-c output voltage is adjustable in five steps, namely, 10,000, 9750, 7500, 6300, and 5000 volts, by primary taps on the plate transformers controlled by a handwheel with which an interlock switch is associated to disconnect the power whenever the taps are changed. Two power supply sources are required: (1) 220 volt, 60 cycle single-phase for the filaments and control circuits; (2) 2300 volt, 60 cycle, three-phase for the plate circuit. The filament voltage is stabilized by automatic voltage regulators which also limit current surges occurring when voltage is applied to the filaments. Tube temperatures are controlled by air cooling provided by a blower working into a duct system.

Plate power is applied to the rectifier through a primary oil circuit breaker equipped with undervoltage, a-c over-current and d-c over-current protection. D-C voltage is supplied to one or both of two power amplifiers through oil switches which can be closed electrically only at push-button stations on the respective power amplifiers. They can be opened or closed manually at the rectifier and are opened automatically when the rectifier plate power is disconnected.

When plate voltage is applied to a mercury vapor rectifier, the filter condenser offers a very low impedance to the transient so that a current surge occurs which frequently damages the tubes in the absence of preventive measures. In this unit, a charging resistor is connected in series with the filter condensers; a relay with normally open contacts operates to short circuit this resistor 1/25 second after the plate voltage is applied.

Puncture of the filter reactor insulation by overvoltages set up by keying or switching transients is prevented by thyrite disks connected between the reactor output terminal and ground. The reactor is connected in the low potential or negative lead to minimize voltage strain on its insulation; it is also protected by a sphere gap.

8. SPECIFICATIONS

The following table of specifications summarizes the foregoing equipment description:

Service: CW radio telegraphy; MCW radio telegraphy; capable of telephone and broadcast operation.

Frequency Range: 5700–22,000 kc. Six pre-set frequencies. Change can be made between any two pre-set frequencies in less than five minutes.

Power Output: 30 kw telegraphy; 9 kw telephone or broadcast.

Frequency Control:

Crystal: $\pm 0.01\%$ of specified frequency. Temperature coefficient less than 2 parts per million per degree Centigrade.

Self-Excited: Output frequency can be set within 0.5% of any frequency. Output frequency remains within 0.01% of the original frequency during any period of 15 minutes continuous operation. Output frequency remains within 0.1% of the original frequency during a period of 12 hours continuous operation.

Output Circuits: On any multiple of the carrier frequency, the harmonic output is at least 45 db below the carrier. The output circuit is designed for two-wire connection to the antenna. The transmitter is capable of delivering its rated output at any frequency between 5700 and 22,000 kc into a two-wire transmission line of 600 ohms surge impedance and with possible standing wave ratios of 2 to 1. Into this line the transmitter provides an output balanced on the two wires.

Reduced Power Output: The transmitter is so arranged that the final amplifier and main high voltage rectifier can be removed from the circuit and the transmitter operated with a power output of 1 kw. Output terminals, coupling circuits and a special switch are provided for this purpose on the next to the last amplifier stage.

Filament Voltages: No vacuum tube operates with a filament voltage in excess of the value recommended by the tube manufacturer for normal tube life.

The equipment is arranged to apply automatically full filament and plate voltages with the time delays recommended by the tube manufacturer. During the starting sequence, the filament current in no tube with directly heated filament and plate dissipation in excess of 100 watts exceeds 175% of the filament current of the same tube when completely heated.

Controls are provided for adjusting and indicating the filament voltage of all tubes except the oscillator which is regulated automatically.

Power Supply: The transmitter requires a 2300-volt and a 220-volt supply, both three-phase 60 cycle.

Telegraph Keying: The transmitter keys satisfactorily up to 400 WPM. The output during spacing intervals is essentially zero. Electronic keying is used and is provided with a control on the front of the transmitter for controlling the weight of the keyed characters, i.e., changing the percentage marking and spacing on dots.

Monitoring Facilities: The following monitoring facilities are provided, each of which produces an output of at least 10 volts rms:

1. Rectified output of the whole transmitter to permit oscilloscope observation of keyed characters or modulation wave-form.
2. Same as (1) for the driver unit.

III. Mechanical Construction

(a) GENERAL

The complete equipment for telegraph operation is supplied in four mechanically independent units. These four units are:

R.F. Driver
Power Amplifier
3000-Volt Rectifier
10,000-Volt Rectifier

The R.F. driver unit and the power amplifier unit must be bolted together with the power amplifier at the right when viewed from the front. This is necessary in order to allow short direct radio frequency connection between these two units and to equalize the R.F. voltages induced in the two frames. The remaining units may be located as desired.

The R.F. driver, power amplifier and 3000-volt rectifier are each built around a frame of steel angle members with the required shelves and partitions for mounting and shielding the various components. The frames are totally enclosed with rear doors for access. The 10,000-volt rectifier is built around a pipe frame enclosed with panels on front and sides and with a grille

on the rear. All the units are uniformly finished with gray wrinkle enamel.

(b) R.F. DRIVER UNIT

The R.F. driver unit is 82 inches high, 36 inches wide and $24\frac{1}{2}$ inches deep. All controls are on the front panel except the taps on the output coupling coil and the taps on the special type balancing network inductances which are accessible by doors on the rear. These doors are perforated for cooling and backed with screening to prevent the entrance of insects. Power and control circuit connections are made to terminals at the lower rear. The antenna connection is made to two terminals on the top; the power amplifier is connected through an insulating bushing on the upper right side panel.

The frame is divided by shelves into four compartments. The bottom compartment houses the blower and the power equipment. The next compartment is constructed like a filing cabinet drawer and can be readily removed; it contains the oscillator, buffer, doublers and phase modulator. Directly above is the first driver stage compartment. The top compartment houses the final driver stage and the output circuits.

(c) POWER AMPLIFIER UNIT

The power amplifier unit is 82 inches high, $55\frac{1}{2}$ inches wide and 40 inches deep. It is divided into four completely shielded compartments. The two top compartments house the filament transformers and the special type balancing network. The lower left compartment contains the grid circuit components including the bias voltage rectifier. The remaining compartment contains the type F-124-A tube, its plate circuit components and the output coupling circuit components. Rear accessibility is provided by four doors which cover the entire rear area of the frame. A door on the left side gives added accessibility to the grid compartment.

All controls are on the front panel except the adjustment for the plate, coupling, and network inductances which are adjusted from the rear by opening the doors. All connections except R.F. are made at the lower rear of the unit. Two terminals on the top provide connection to the antenna. An opening in the upper left side opposite the bushing on the R.F. driver unit is

provided through which the lead supplying the R.F. power for driving the unit is passed.

(d) 3000-VOLT RECTIFIER UNIT

The 3000-volt rectifier is mounted in a frame 51 inches high, 32 inches wide and 25 inches deep. Its construction is similar to that of the two radio frequency units. All controls are on the front panel and rear accessibility is provided by doors.

(e) 10,000-VOLT RECTIFIER UNIT

The 10,000-volt rectifier unit is 114 inches high, 89 inches wide and 114 inches deep. All controls are on the front panel except the tap

changing handwheel which may be located on either side panel at the rear. A door in the center of each side opens on a passageway which extends across the unit. This passageway divides the rectifier into a front and a rear section. The rear section contains the transformers, filter components, and tubes while the front section contains the metering and control equipment. The top and bottom of the frame are left open. All equipment, such as transformers which are not attached to the frame, are mounted on the floor within the enclosure.

One installation, as herein described, has been purchased by All America Cables and Radio Inc. for use in the expansion of its International service at Lima, Peru.

Recent Telecommunications Developments

AVIATION RADIO.—The Civil Aeronautics Administration carried out a series of field tests on various types of aural four-course U.H.F. radio ranges at Indianapolis, Indiana, and Van Nuys, California. These tests indicated that radical changes were necessary in the antenna system for the ranges. The design for these improved antennas was based upon developments by the International Telephone & Radio Manufacturing Corporation, and during 1941 eight of the improved radio ranges were installed in the New York–Chicago airway. This airway is now under test but indications are very definite that the four-course aural range will be superseded by the two-course range noted below.

An ultra-high frequency two-course visual radio range with aural quadrant identification was developed by the engineers of I.T. & R.M. for the C.A.A. during 1941. This important new aid to air navigation was demonstrated on October 30, 1941 at the Indianapolis Municipal Airport to members of the radio range subcommittee of the Radio Technical Commission for Aeronautics. After extensive flight tests, participated in by airline pilots, the range received unanimous approval. It is quite likely that this type of radio range will be adopted for the civil airways of the U.S.A. and that several hundred will be installed throughout the country.

The Federal Telegraph Company, a unit of the International Telephone & Radio Manufacturing Corporation, is in process of completing the manufacture of a fourth order of simultaneous long wave radio range stations for the C.A.A. More than 70 percent of the total number of these range stations in use in the U.S.A. are of the Federal Telegraph type.

U.H.F. Marker Antenna Systems have been the subject of some development work and improvement, and C.A.A. engineers, recently, set up and tested at Indianapolis, Ind., an improved type of Z marker antenna system. Radiation from this type of marker is sharper than from previously used types and is substantially free from secondary lobes.

The Civil Aeronautics Administration has awarded the Federal Telegraph Company a con-

tract for the manufacture of ten instrument landing system equipments intended for installation at principal U.S.A. airports. This contract is in addition to one previously recorded in this journal for systems, now in process of installation, at La Guardia Field and other airports.¹

This instrument landing system,² permits fliers to land entirely by instruments. Many fliers already have been trained in its use, and these installations are intended to familiarize all commercial airline pilots throughout the country with its operation as a vital additional safeguard against sudden bad weather.



NEW ARGENTINE BROADCASTING CHAIN.—Red Argentina De Emisoras Splendid (RADES) has contracted with Compañía Standard Electric Argentina, Buenos Aires, a subsidiary of the International Standard Electric Corporation, for eight medium wave broadcasting stations. LR4 (Radio Splendid), Buenos Aires, will be powered at 50 kw; LW1 (Radio Cultura), Cordoba, and LT2 (Radio Stentor), Rosario, at 20 kw; LU3 (Radio Del Sur), Bahia Blanca, and LV6 (Radio Mendoza), Mendoza City, at 10 kw; and LT4 (Radio Misiones), Posadas, LU5 (Radio Neuquen), Neuquen City, and LW7 (Radio Catamarca) Catamarca City, at 1,500 watts. Radio Splendid (LR4), similar to station LS1 of the Municipality of Buenos Aires,³ will incorporate the high efficiency Doherty Amplifier.

These stations are planned to provide coverage for the entire Argentine Republic as well as contiguous areas in sister republics. Facilities for interconnection to outlying stations will include a 25 kw short wave transmitter, which will relay programs from the Buenos Aires station (LR4) and which also will be constructed by C.S.E.A.

¹ *El. Com.*, Vol. 19, No. 3, p. 5, 1941.

² "Development of the C.A.A. Instrument Landing System at Indianapolis, by W. E. Jackson, A. Alford, P. F. Byrne, and H. B. Fischer, *El. Com.*, Vol. 18, No. 4, 1940.

³ "Broadcasting Station LS1–Buenos Aires," by R. E. Coram, A. W. Kishpaugh, and W. H. Capen, *El. Com.*, Vol. 17, No. 1, 1938.

Broadcast program circuits of the United River Plate Telephone Company, Limited, in certain cases, will be utilized for interconnection purposes.

This is the first time that any South American firm has undertaken the production and installation of a complete chain of broadcasting stations on the scale projected. The contract also is the largest single one for broadcasting stations ever awarded in South America.

• • •

COLUMBIA BROADCASTING SYSTEM'S NEW SHORT WAVE TRANSMITTERS WCRC AND WCBX.—Following closely on the placing in service of the 50 kw Broadcasting Station WABC, C.B.S., on January 1, 1942, inaugurated two short wave transmitters for international broadcasting. These also were designed and built by the Federal Telegraph Company, a unit of the International Telephone & Radio Manufacturing Company. To accommodate the short wave transmitters, the Mackay Radio and Telegraph Company constructed an addition to its main transmitting station at Brentwood, Long Island, New York.

The transmitters consist of three driver units and associated power amplifiers of 50 kw carrier power output capable of 100 percent modulation. Two modulator units and power supplies are provided to permit simultaneous operation of two transmitters while the third power amplifier is lined up for immediate program switching to another high frequency band. Special features not previously employed in similar transmitters include line type tank circuits and an ingenious antenna switching arrangement which permits connecting any transmitter to any of the numerous antennas.

For use with these transmitters Mackay Radio designed and constructed thirteen high gain antennas directed on Europe, Central and South America. Three of the antennas are reversible so that they can be used at different hours to northern Europe and to Mexico and Central America. In anticipation of future developments, the antenna insulation and provisions for avoiding corona are in excess of anything previously constructed in the short wave field in the U.S.A.

MACKAY RADIO AND TELEGRAPH COMPANY.—The Company has improved and extended its ultra-high frequency radio circuits used as keying and tone lines between central offices and the transmitting and receiving stations. The circuits include transmitters working in the 156 and 160 megacycle band modulated by as many as sixteen separate tone channels. Very effective high gain directive antennas were developed for use on these circuits. Among interesting features, the antennas embody provision for reducing the effects of ice or sleet accumulations. Circuits of this type now in service are as follows:

New York to Brentwood (New York): 40 miles, 16 channels

Brentwood to Southampton (New York): 45 miles, 3 channels

Southampton to Brentwood (New York): 45 miles, 9 channels

San Francisco to Palo Alto (California): 28 miles, 16 channels.

An 85-mile circuit between Southampton and New York with intermediate relay at Brentwood is in experimental operation, and circuits in both directions between Southampton and Amagansett, 18 miles, are under construction.

Mackay Radio from New York, recently inaugurated direct radiotelegraph service to Foynes, Eire, Moscow, U.S.S.R., and La Paz, Bolivia; also a circuit between San Francisco and Khabarovsk, U.S.S.R. Tests are being conducted between Honolulu, Hawaiian Islands, and Chungking, China, and between San Francisco and Wellington, N. Z., involving circuits which it is planned to open shortly for regular traffic. It added new equipment to its coastal station at Jupiter, Florida, to provide improved service to ships in the South American and Caribbean trade, making this station the most powerful in the Southeastern region of the U.S.A. Its fourth marine service station was opened in the region of the Gulf of Mexico at Mobile, Alabama.

• • •

TOLL PLANT ADDITIONS IN THE STATES OF RIO GRANDE DO SUL AND PARANA, BRAZIL.—In 1939 Companhia Telefonica Rio Grandense

began construction of a main toll route from Porto Alegre west to Santa Maria in the State of Rio Grande do Sul. Since that time extensions have been carried out from Santa Maria to the cities of Cruz Alta, Ijuí, Santo Ângelo, São Pedro, São Gabriel, Don Pedro and Bage.

During 1941 toll construction was continued between São Gabriel and Rosario, a distance of about 64 kilometers. This construction represents a further step in the extension of toll facilities to the western part of the state looking towards eventual land line connection with Argentina. It is anticipated also that the São Gabriel-Rosario construction will be completed early in 1942 and that it will be extended to Livramento on the

Uruguayan border, a distance of about 109 km. When completed, international connection will be established with Uruguay through Rivera, situated opposite Livramento.

The Companhia Telefonica Paranaense in 1941 extended the Curitiba-Castro portion of its main toll route into the northern part of the State of Parana by the completion of the Castro-Santo Antonio da Platina section, a distance of about 39 km. This is part of a proposed 240 km extension to connect the rich northern agricultural part of the state with the capital city of Curitiba. On completion, this project will be the means of connecting the Company's network with certain other important Brazilian cities.

INTERNATIONAL TELEPHONE AND TELEGRAPH CORPORATION

Associate Companies in the Western Hemisphere

UNITED STATES OF AMERICA

INTERNATIONAL STANDARD ELECTRIC CORPORATION: *Manufacturer and Supplier of Communication and Other Electrical Equipment Through Licensee Companies Throughout the World; Exporter of Communication and Other Electrical Equipment.*.....New York, N. Y.

INTERNATIONAL TELEPHONE & RADIO MANUFACTURING CORPORATION: *Manufacturer of Communication and Other Electrical Equipment.*.....East Newark, N. J.

FEDERAL TELEGRAPH COMPANY: *Manufacturer of Radio Equipment.*.....Newark, N. J.

COMMERCIAL CABLE COMPANY: *Trans-Atlantic Telegraph Service.*.....New York, N. Y.

COMMERCIAL PACIFIC CABLE COMPANY: *Trans-Pacific Telegraph Service.*.....New York, N. Y.

MACKAY RADIO AND TELEGRAPH COMPANY: *International, Domestic and Marine Radio Telegraph Services*
New York, N. Y.

ALL AMERICA CABLES AND RADIO, INC.

All America Cables and Radio, Inc. maintains 67 Company-owned telegraph offices in 23 countries and islands throughout Central and South America and the West Indies......New York, N. Y.

THE CUBAN ALL AMERICA CABLES, INC.: *United States-Cuba Telegraph Service.*.....New York, N. Y.

ARGENTINA

*COMPANÍA STANDARD ELECTRIC ARGENTINA: *Manufacturer of Communication and Other Electrical Equipment*Buenos Aires

COMPANÍA INTERNACIONAL DE RADIO (ARGENTINA): *Radio Telephone Service.*.....Buenos Aires

SOCIEDAD ANÓNIMA RADIO ARGENTINA: *Radio Telegraph Service*Buenos Aires

COMPANÍA TELEFÓNICA ARGENTINA: *Telephone Operating System.*.....Buenos Aires

COMPANÍA TELEGRÁFICO-TELEFÓNICA COMERCIAL: *Telephone Operating System.*.....Buenos Aires

UNITED RIVER PLATE TELEPHONE COMPANY, LIMITED: *Telephone Operating System.*.....Buenos Aires

BOLIVIA

COMPANÍA INTERNACIONAL DE RADIO BOLIVIANA: *Radio Telephone Service*La Paz

BRAZIL

*STANDARD ELECTRICA, S. A.: *Manufacturer of Communication and Other Electrical Equipment*
Rio de Janeiro

COMPANHIA RADIO INTERNACIONAL DO BRASIL: *Radio Telephone and Telegraph Services.*.....Rio de Janeiro

COMPANHIA TELEFONICA PARANAENSE, S. A.: *Telephone Operating System*Curityba

COMPANHIA TELEFONICA RIO GRANDENSE: *Telephone Operating System*Porto Alegre

CHILE

COMPANÍA DE TELÉFONOS DE CHILE: *Telephone Operating System*Santiago

COMPANÍA INTERNACIONAL DE RADIO, S. A. (CHILE): *Radio Telephone and Telegraph Services.*.....Santiago

CUBA

CUBAN TELEPHONE COMPANY: *Telephone Operating System*Havana

RADIO CORPORATION OF CUBA: *Radio Telegraph Service*
Havana

MEXICO

MEXICAN TELEPHONE AND TELEGRAPH COMPANY: *Telephone Operating System.*.....Mexico City

PERU

COMPANÍA PERUANA DE TELÉFONOS LIMITADA: *Telephone Operating System.*.....Lima

PUERTO RICO

PORTO RICO TELEPHONE COMPANY: *Telephone Operating System.*.....San Juan

RADIO CORPORATION OF PORTO RICO: *Radio Telephone Service and Radio Broadcasting.*.....San Juan

Associate Companies in the British Empire

*STANDARD TELEPHONES AND CABLES, LIMITED
London, England

Branch Offices: Birmingham, Leeds, England; Glasgow, Scotland; Cairo, Egypt; Calcutta, India; Pretoria, South Africa.

*CREED AND COMPANY, LIMITED.....Croydon, England

INTERNATIONAL MARINE RADIO COMPANY, LIMITED
Liverpool, England

*STANDARD TELEPHONES AND CABLES PTY. LIMITED
Sydney, Australia

Branch Offices: Melbourne, Australia; Wellington, N.Z.

*Licensee Manufacturing and Sales Company of the International Standard Electric Corporation, New York, N. Y.